

tk UCE Chlor-Alkali Technologies

CLOROSUR Technical Seminar & WCC Safety Workshop
14 -16 November 2018 Monterrey - Mexico

thyssenkrupp Uhde Chlorine Engineers (Italia) Srl

engineering.tomorrow.together.



thyssenkrupp

thyssenkrupp Uhde Chlorine Engineers – a reliable partner

Building on a strong past – looking into a bright future

- UHDENORA founded as JV 2001 between DeNora (founded 1923) and Uhde (founded 1921)
- Chlorine Engineers founded 1973, acquired in 2011 by Industrie de Nora S.p.A., the parent holding company of De Nora
- ThyssenKrupp Electrolysis GmbH (a carve-out of the former Uhde Product Unit Electrolysis, founded in 1960)

UHDENORA

+



+



ThyssenKrupp Electrolysis

Amounts to

thyssenkrupp
Uhde Chlorine Engineers



To ensure excellent support on a global scale

thyssenkrupp Industrial Solutions and Industrie De Nora joined forces

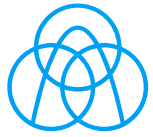

thyssenkrupp

thyssenkrupp
Industrial Solutions

66%

Support:
Engineering, Procurement,
Construction, Financing,
etc.

thyssenkrupp Uhde Chlorine Engineers

Technology, Plant Business (EPC), Services

34%

Industrie De Nora

Supplies:
Coating and cell
manufacture



Our responsibilities are defined across the world

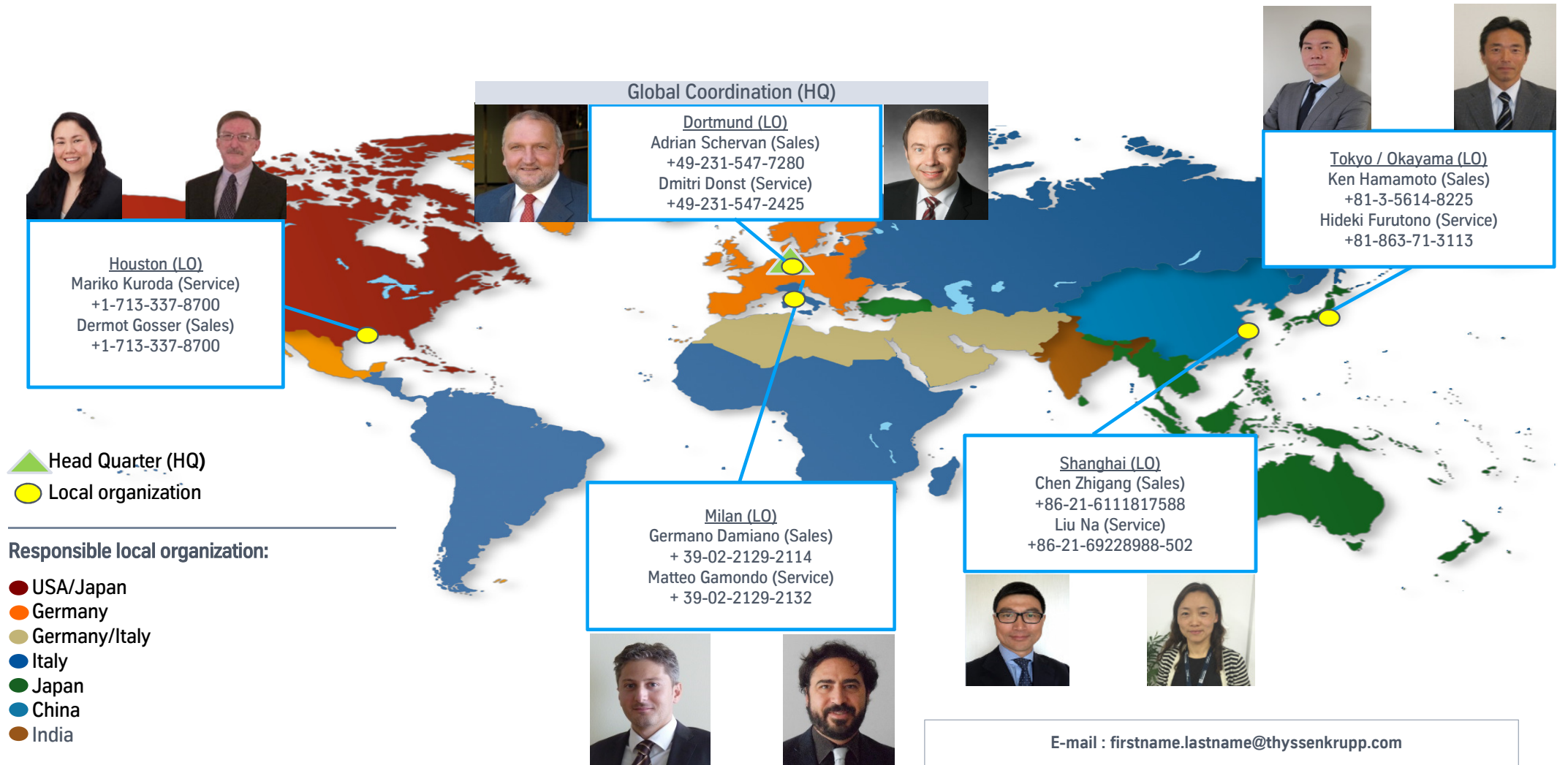

What we offer to our Customers

Business models and services

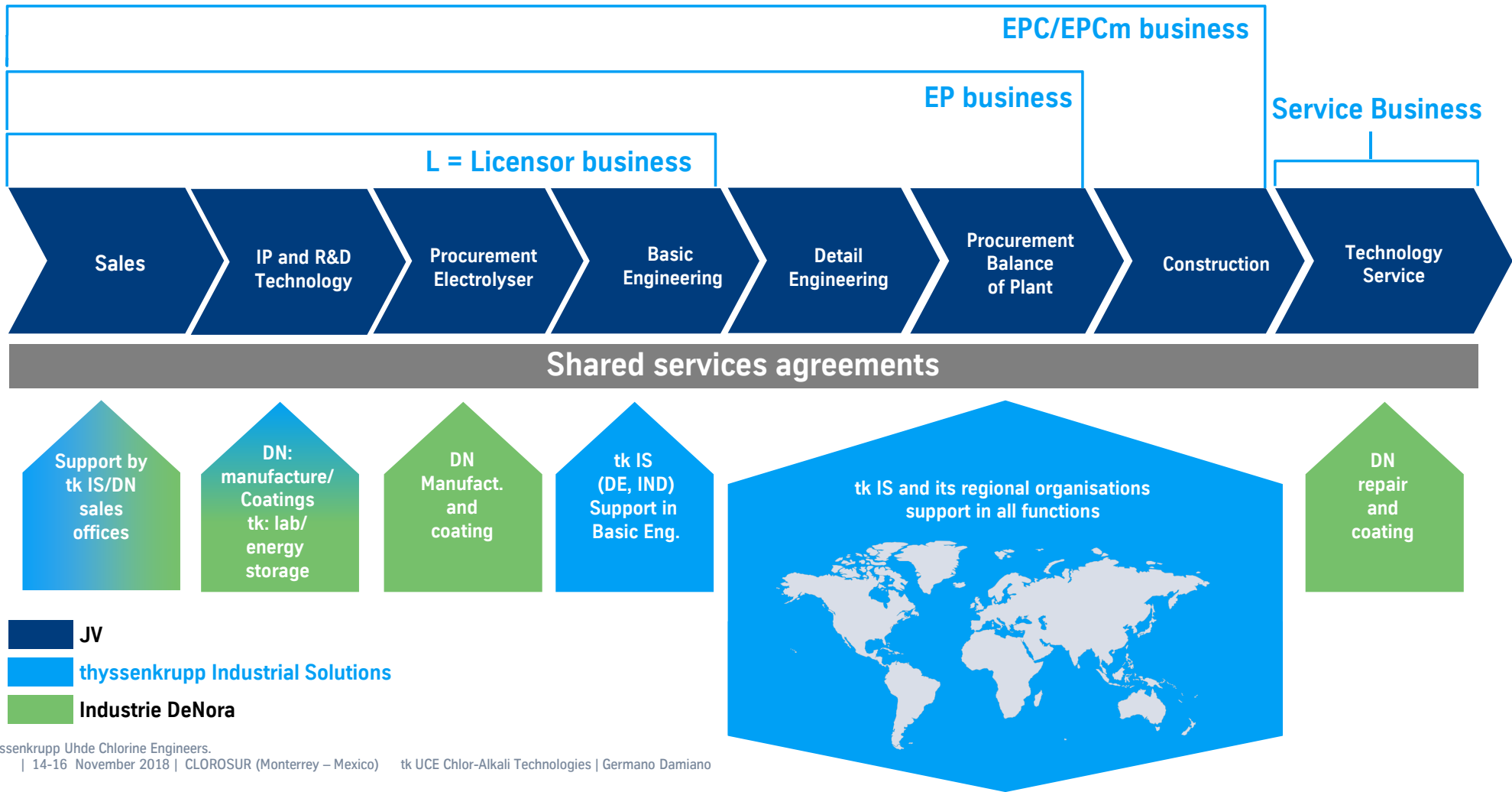

Single Point Responsibility

- The only single source supplier
- Extensive knowledge and experience in all sections of a Chlor-Alkali plant
 - Design Expertise
 - Process Expertise
 - Electrical Expertise
 - Instrumentation Expertise
 - Piping Expertise

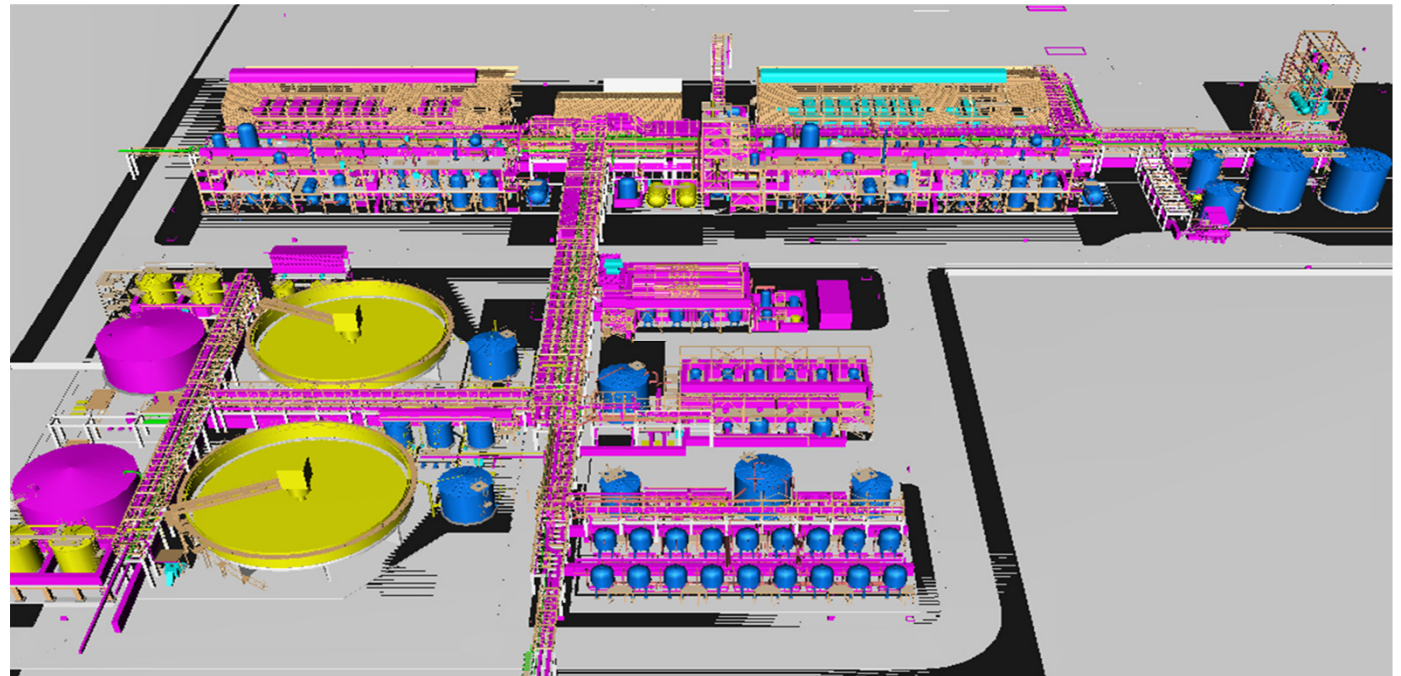

Continuity of the technologies is secured
Our best-in-class technologies are further optimized

Our development targets



**BM Single Element
Technology**
made in
GERMANY



**BiTAC Filter Press
Technology**
made in
JAPAN

**Power consumption
< 2000 kWh/t NaOH**

Broad operating range
(e.g. operability up to 8 kA/m²)

**Further increase of quality,
reliability and efficiency**
(e.g. optimized fabrication, improved
coatings, zero gap membranes)



Our technologies and competencies have been attractive

Accumulated contract awards

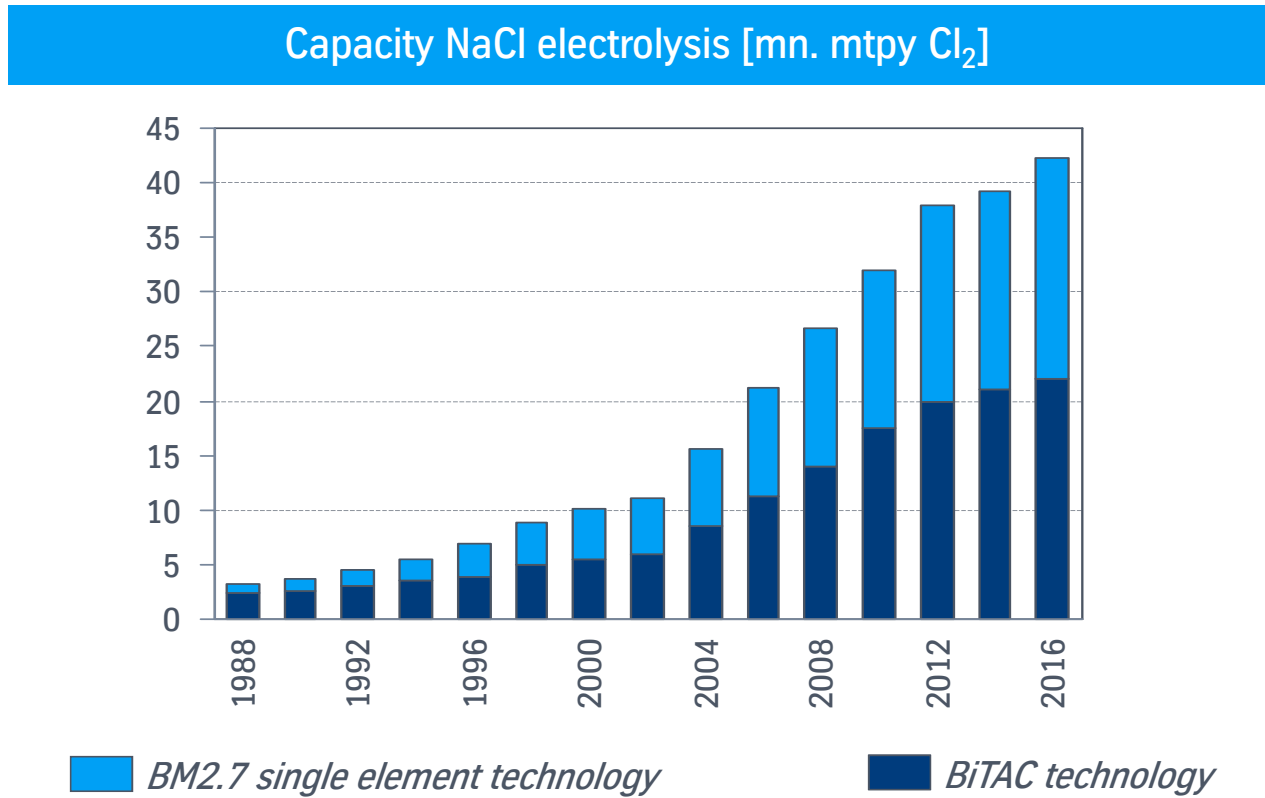

History of BiTAC Series

Continuous improvements over two decades

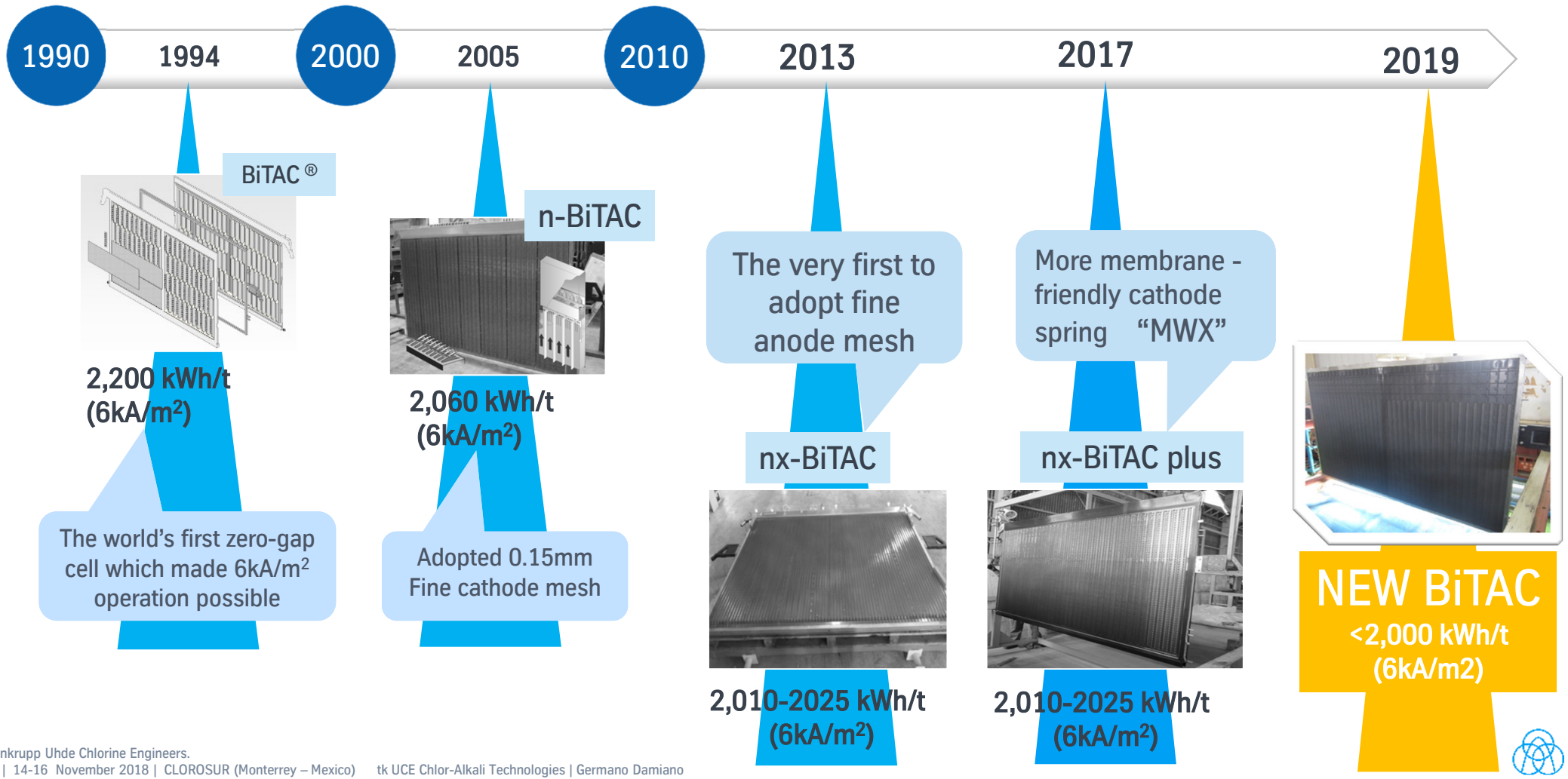

The design of the nx-BiTAC plus elements brings the following benefits:

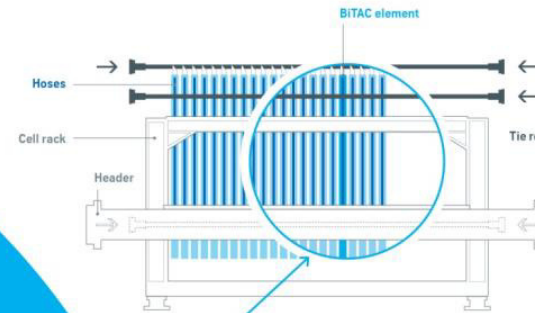
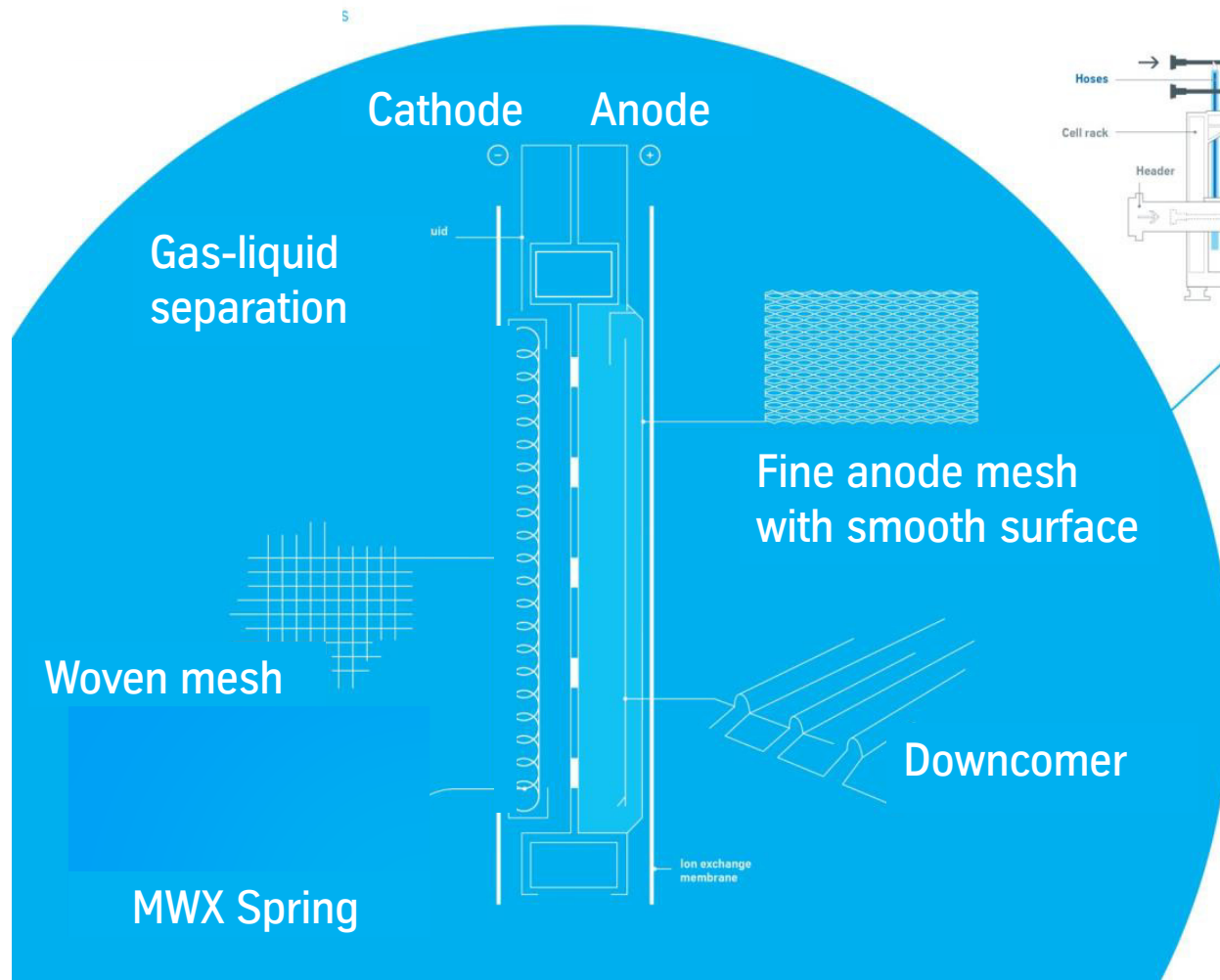

BiTAC filter press technology has specific advantages:

- Low sealing force required for gaskets
- Fast remembraning of complete electrolyzer
- Smaller maintenance area required
- Lower power consumption through joining anode and cathode compartments by explosion bonding
- Higher flexibility of new MWX spring reduces pressure on membranes to increase durability and lower risk of pinhole formation



We come from a strong heritage of technology improvements

History of BM series

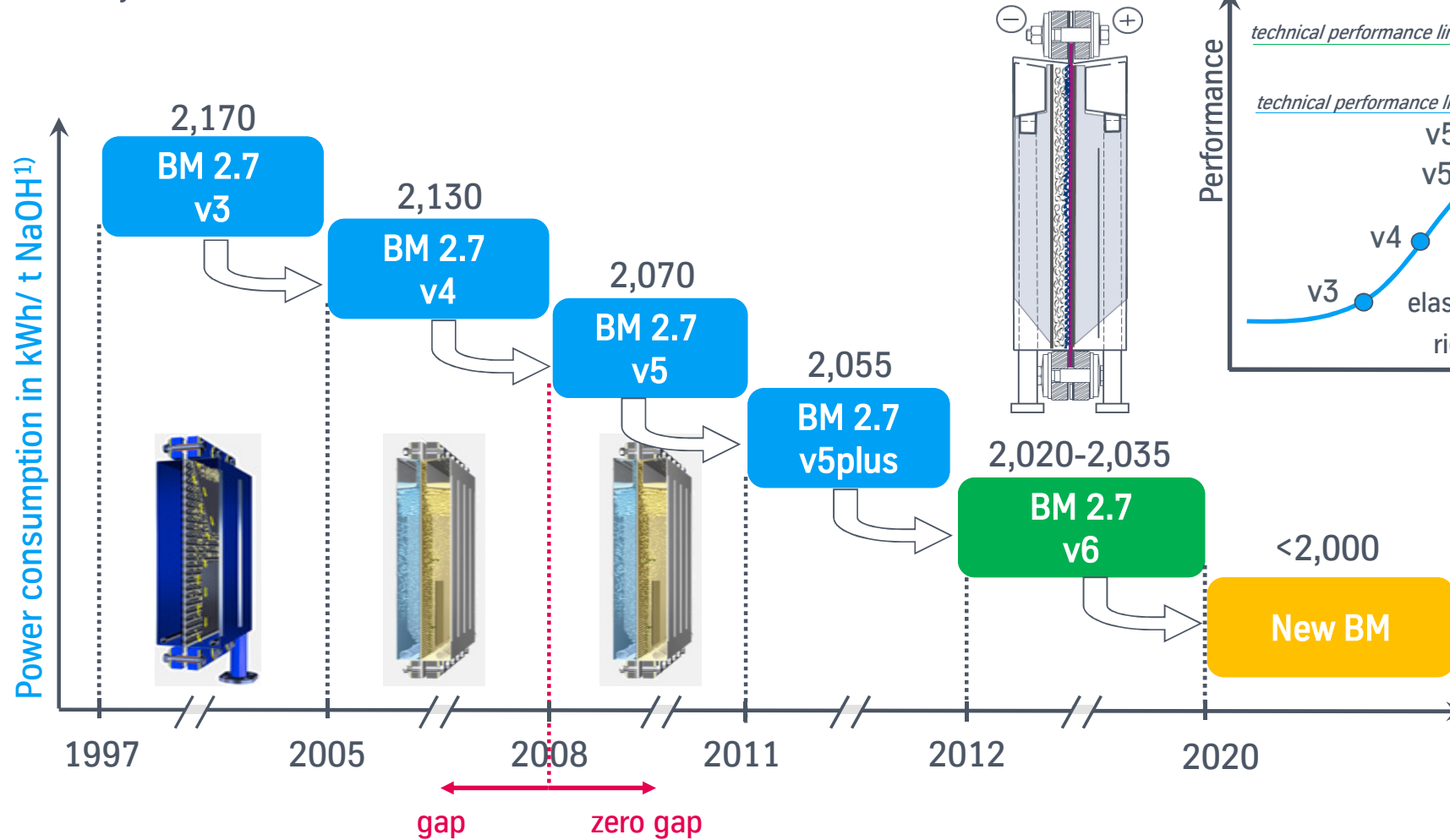

Technology development cycle

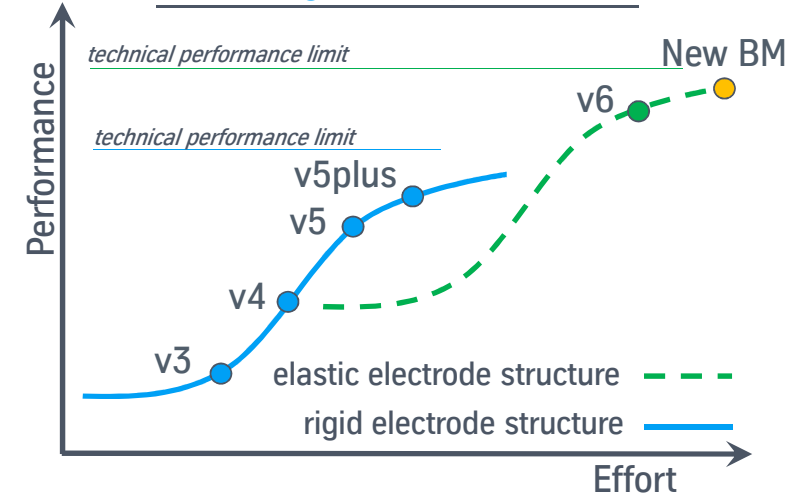

¹⁾ 6 kA/m², 90°C, 32 % NaOH



Every BM2.7 “single-element” is fully assembled and tested before inserting it into the electrolyzer

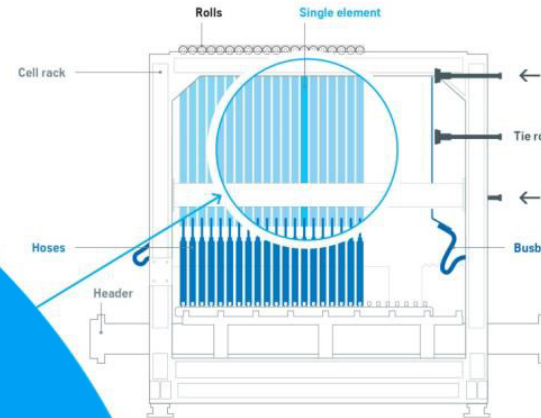
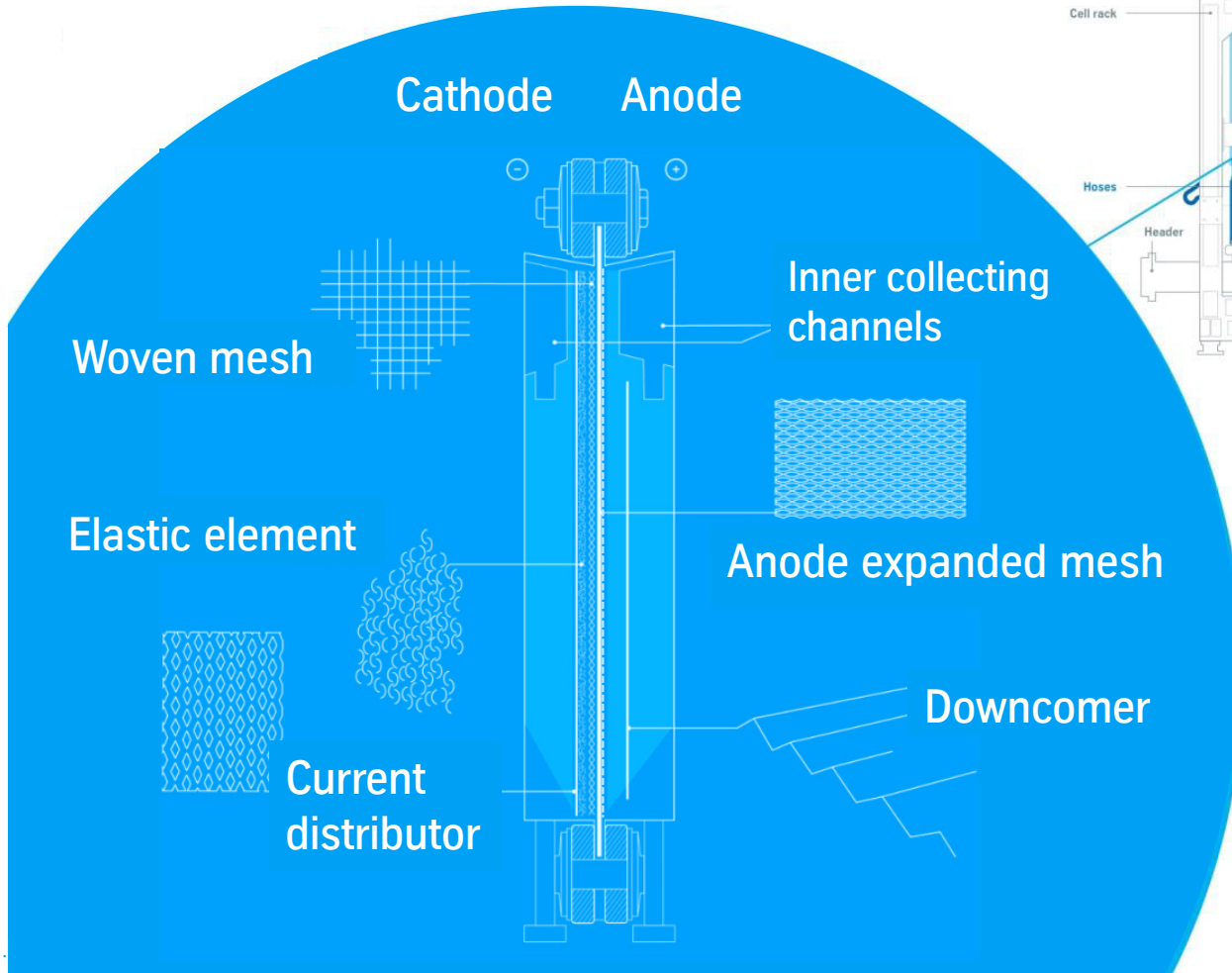

BM2.7v6 advantages

- Unique sealing and hose system, 100% leakproof up to 4.7 bar_g (operating pressure: < 0.5 bar_g)
- Roller suspension of each single-element ensures precise adjustment of stack compression
- Hard, long-wearing PTFE gaskets
- Assembly and testing of elements in clean area outside cell house
- Elements can be stored for months
- Fast and simple replacement
- Low failure rate



Conversion of Hg plants

The largest worldwide experience

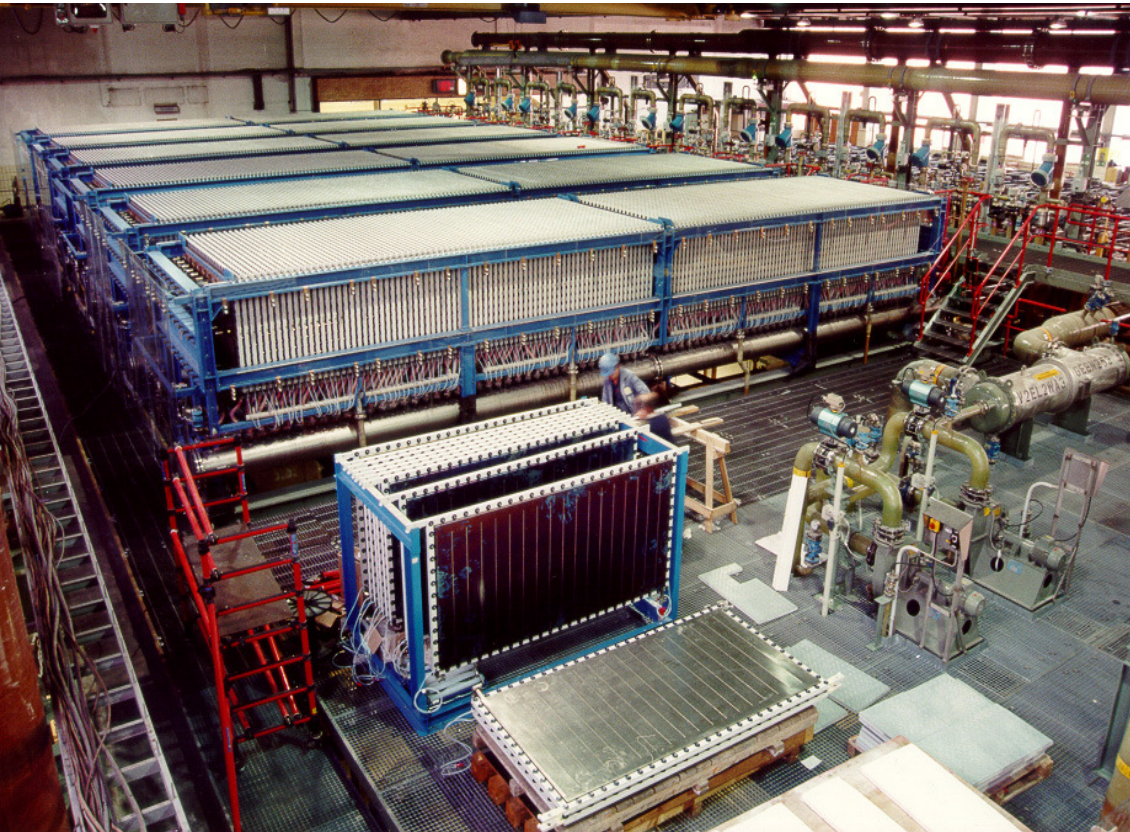

- Partial or complete conversions, expansion of capacity
- Possible re-use of existing infrastructures
- Minimize investment, production loss, plant shutdown

We support you to define
the best concept



Extensive knowhow and experience in all type of conversion projects

Number of conversion projects

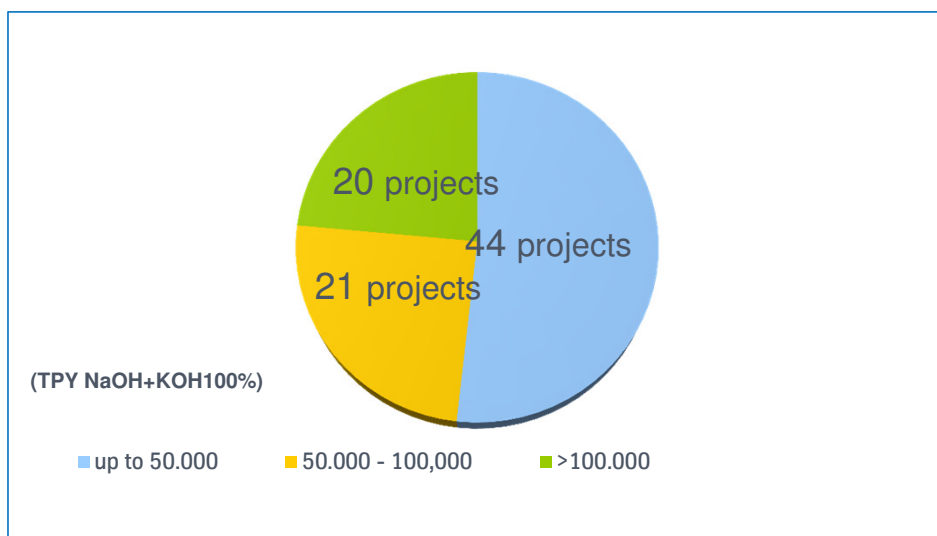

Cumulative Installed Conversion Capacity by Project Size

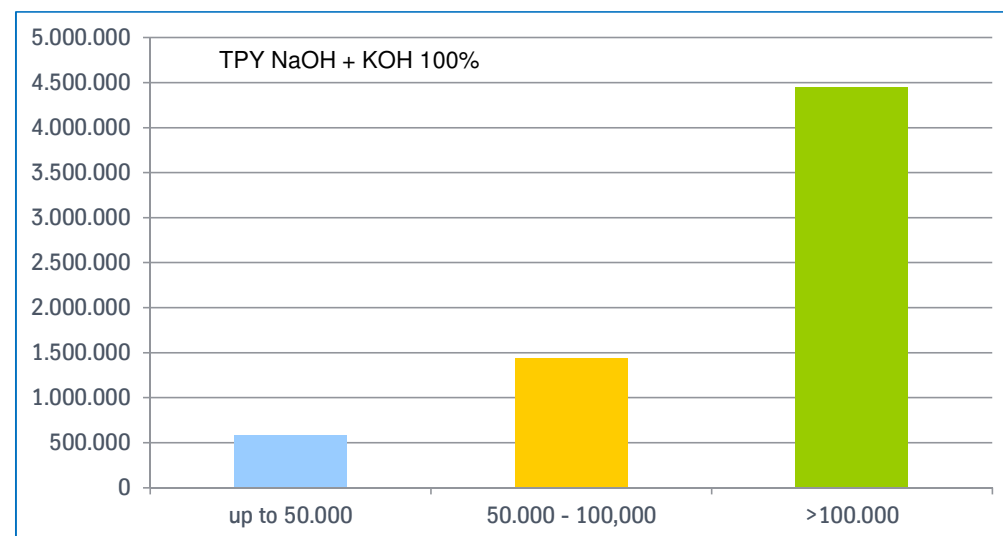

More than 80 conversion projects > 6 Mio TPY (NaOH + KOH 100%)



Skid mounted plants



Plant for Produquimica (Brazil)

- Fully assembled & tested skid units
- For small-scale chlorine production, debottlenecking, capacity increase, fast implementation, projects, remote locations, ...
- Low installation cost

Easy transport,
“plug & play” installation



Skid units from workshop to site



pre-assembled in workshop



connected together in the final field configuration



checked under UCEI supervision



combined with other elements to complete process unit



transported to site



An easy and fast installation on site



NaCl-ODC electrolysis (oxygen depolarized cathode)

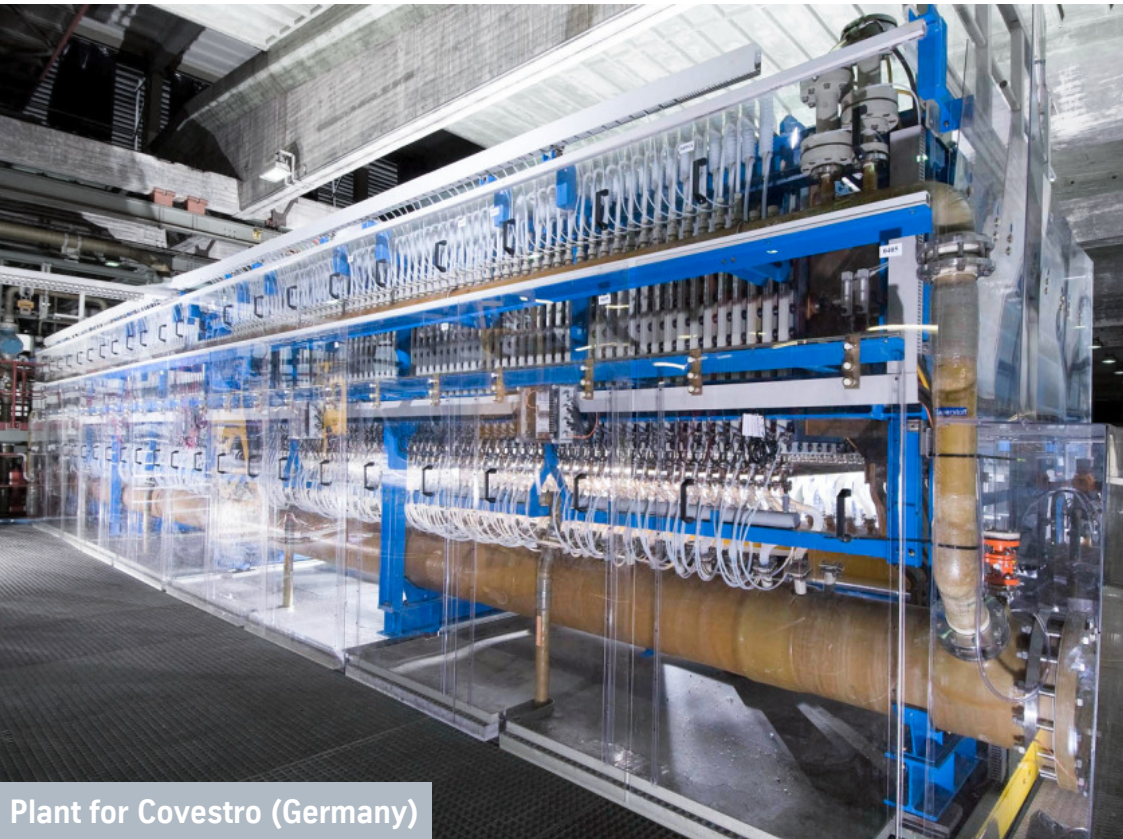

Plant for Covestro (Germany)

- Worldwide unique technology, developed by tkUCE and Covestro
- Oxygen introduced into cathode suppresses unwanted hydrogen formation
- Easy integration into existing plants

~25% less energy consumption



Successful market entry of NaCl-ODC technology

NaCl-ODC technology

Demonstration
Full industrial scale



Covestro, Uerdingen Germany¹⁾

Demonstration
Indian market

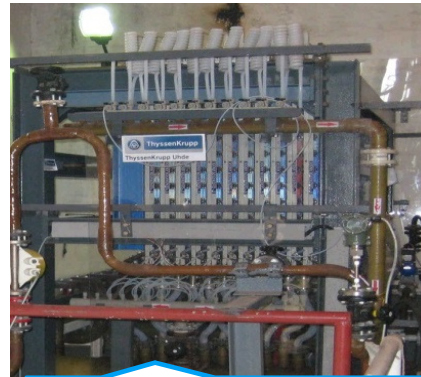

Grasim, Aditya Birla Nagda India

Commercial plant
Chinese market



Befar Group, Binzhou, China.

Greenfield Commercial plant
European market



Covestro, Tarragona, Spain.

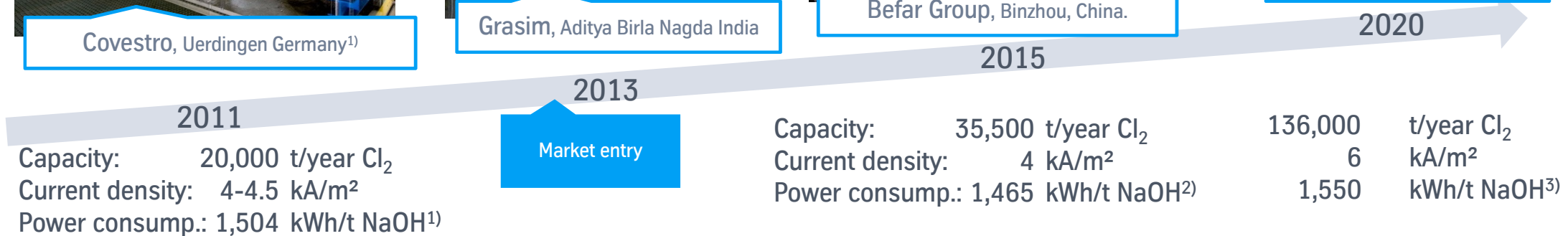

Five years of reliable operation in industrial plant scale

1) Average over 5 years, picture copyright of company Covestro 2) Average over 1 year 3) Expected at Start-up



Selected References

Conventional plants (BM – BiTAC)



Customer: Tessenderlo
Location: Belgium
Capacity: 306,000 t/year of NaOH
272,000 t/year of Cl₂
Process: tk UCE
Commissioning: 2006
Speciality: EPC

Key Highlights:
Steel Structure: ~ 2500 tons
Soil removal: ~ 12000 m³
Piping material: ~ 450 tons
Static Equipment: ~ 600 tons
P&ID's: ~ 130 dwgs.
LV Motors: ~ 95 nos.
MV Motors: for Cl₂/H₂ compressor
Installed Power: ~ 100 MVA for TR,
~ 7 MVA for motors
I/O's: ~ 3500 nos.



Customer: HALO INDUSTRIES
Location: Torviscosa, Italy
Capacity: 25,500 t/year of NaOH
Process: Chlor-Alkali
Licence: tk UCE
Commissioning: November 2017
Contract: EPC

Electrolyzer /Scope: nxBiTAC / Process units



Selected References

Hg Conversion

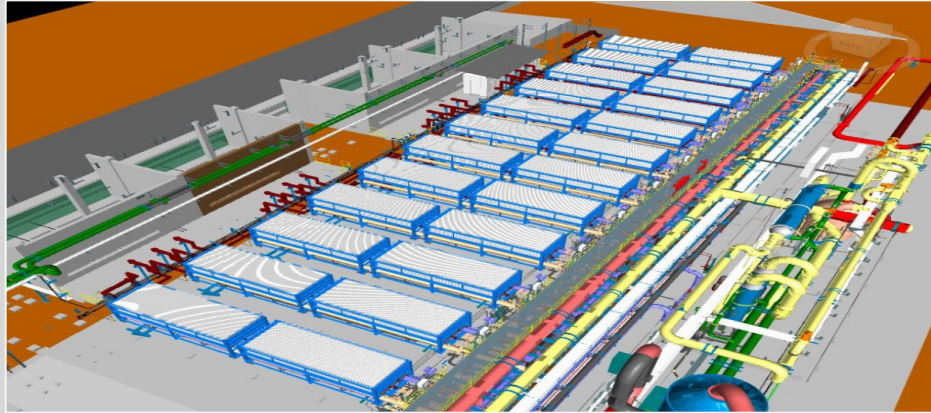

Customer: KEM ONE,
Lavera, France
Capacity: 400,000 t/year of Cl₂
Process: Chlor-Alkali
Licence: tk UCE
Commissioning: 2017
Contract: EP

Key Highlights: Hg + Diaphragm Conversion

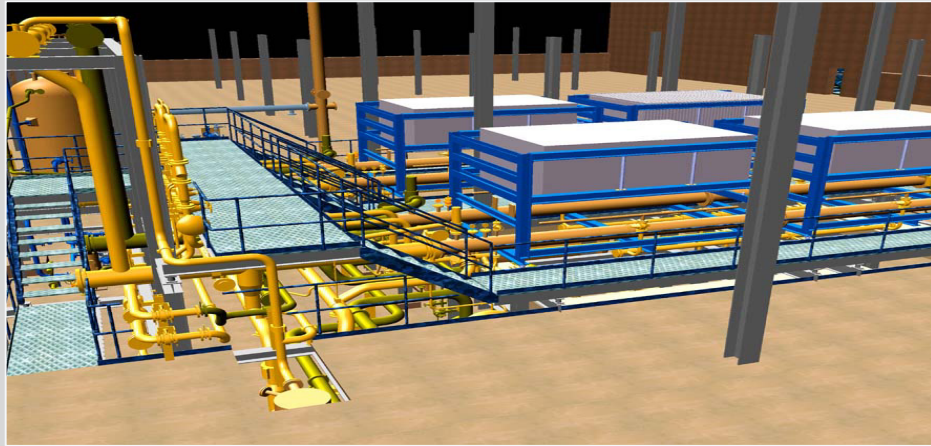

Customer: PCC Rokita SA,
Brzeg Dolny, Poland
Capacity: 62,285 t/year of Cl₂
Process: Chlor-Alkali
Licence: tk UCE
Commissioning: 2015
Contract: EP

Key Highlights: Hg Conversion



Selected References

Hg Conversion

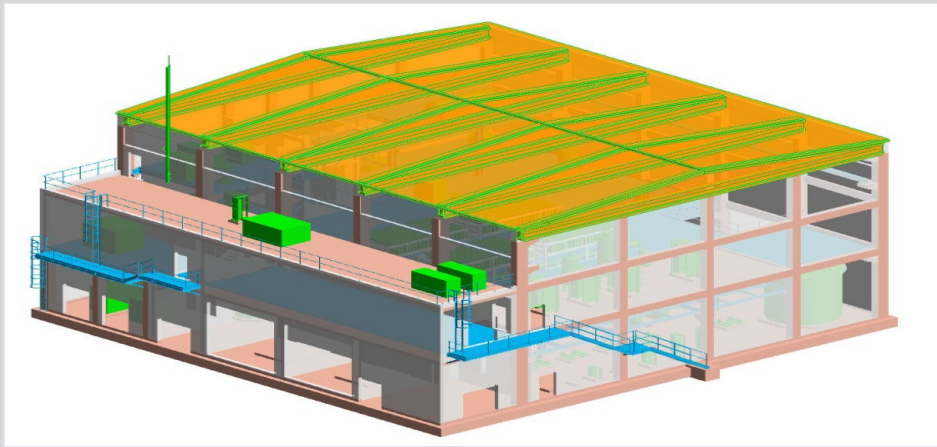
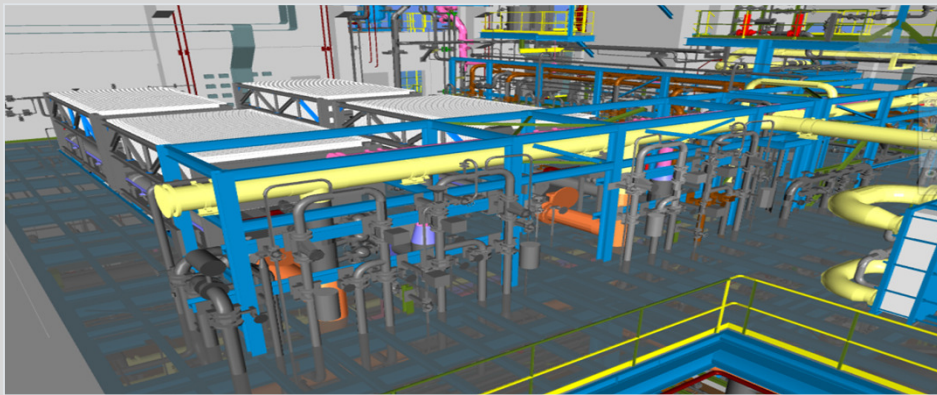

Customer: CABB AG,
Location: Pratteln, Switzerland
Capacity: 47,000 t/year of Cl₂
Process: Chlor-Alkali
License: tk UCE
Commissioning: OCT - 2016
Contract: EPC LSTK

Key Highlights: Hg Conversion

Piping: ~ 650 lines
Static Equipment: ~ 47 specifications
Rotating equipment: ~ 24 specifications
Package equipment: ~ 3 packages
P&ID's: ~ 50 dwgs.
LV Motors: ~ 50 nos.
MV Motors: for Cl₂/H₂ compressor
I/O's: ~ 1134 nos.
Concrete: ~ 2500 m³



Selected References

Skid Mounted Chlorine Plants

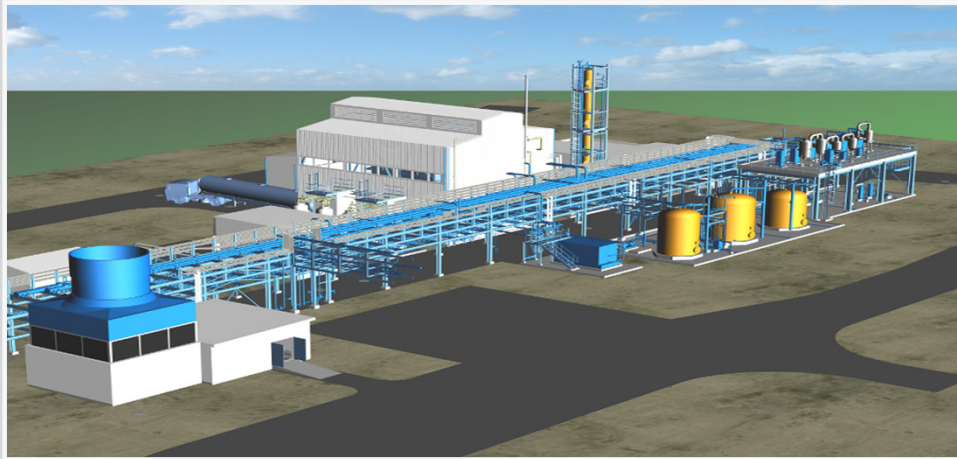

Customer: Leuna-Harze GmbH,
Location: Leuna, Germany
Capacity: 15,000 t/year of Cl₂
Process: Chlor-Alkali
Licence: tk UCE
Commissioning: 2012
Contract: EPC LSTK

Key Highlights:
Project: Skid Mounted Chlorine Plant
(total 16 skids)

Scope of Supply: Electrolysis, Catholyte Circulation, Brine Dechlorination, Cl₂ and H₂
Cooling and Filtration
Brine Filtration
Secondary Brine Purification
Waste Gas Dechlorination
Sodium Hypochlorite Production



Selected References

Skid Mounted Chlorine Plants



Customer: Produquimica Industria & Comercio

Location: Brazil

Capacity: 17,000 t/year of NaOH
15,000 t/year of Cl₂

Process: tk UCE

Commissioning: 2014

Specialty: EP

Key Highlights:

Project: Skid Mounted Chlorine Plant
(total 7 skid mounted process units)

Scope of Supply: Electrolysis, Catholyte Circulation,
Brine Dechlorination, Cl₂ and H₂ Cooling and Filtration
Brine Filtration
Secondary Brine Purification
Waste Gas Dechlorination
Sodium Hypochlorite Production
Chlorine Drying



Selected References

Oxygen Depolarized Cathode (NaCl-ODC) Chlor-Alkali Electrolysis



Customer: Befar Group Co, Ltd
Location: P.R. China
Capacity: 40,000 t/year of NaOH
35,500 t/year of Cl₂
Process: tk UCE / Covestro
Commissioning: 2015
Specialty: L (EP)

Key Highlights:

Technology: NaCl-ODC (Oxygen Depolarized Cathode)
Project: Plant Expansion
Scope of Supply: BM-ODC Electrolyzers
Electrolysis Room Accessories
Key Catholyte Circulation Equipment
Uhde EVALUATOR Monitoring System



Globally leading technologies for chlorine and caustic soda production



BM single element



NaCl-ODC



BiTAC filter press



Skid mounted plants

Thank you for your attention

engineering.tomorrow.together.



thyssenkrupp