



THE CHLORINE INSTITUTE

Pamphlet 1

Chlorine Basics

Edition 8



May 2014



Table of Contents

1.	INTRODUCTION	1
1.1	CHLORINE BASICS	1
1.2	CHLORINE INSTITUTE STEWARDSHIP PROGRAM.....	1
1.3	DISCLAIMER	2
1.4	APPROVAL.....	2
1.5	REVISIONS	2
1.6	SIGNIFICANT REVISIONS IN CURRENT EDITION.....	2
1.7	CHECKLISTS.....	2
1.8	ABBREVIATIONS AND ACRONYMS.....	2
2.	GENERAL INFORMATION	4
2.1	WHAT IS CHLORINE?.....	4
2.2	CHLORINE MANUFACTURE	4
2.3	CHLORINE TRANSPORTATION.....	7
2.4	OTHER REGULATORY ASPECTS.....	7
2.5	TERMINOLOGY.....	8
2.6	SPECIFIC MANUFACTURING AND USE HAZARDS	10
3.	CYLINDERS AND TON CONTAINERS.....	11
3.1	CONTAINER DESCRIPTIONS.....	11
3.2	CONTAINER VALVES	13
3.3	PRESSURE RELIEF DEVICES.....	14
3.4	CONTAINER SHIPPING.....	14
3.5	CONTAINER MARKING/LABELING AND VEHICLE PLACARDING	15
3.6	CONTAINER HANDLING.....	15
3.7	CONTAINER STORAGE	16
3.8	CONTAINER USE.....	16
4.	BULK SHIPPING CONTAINER	18
4.1	GENERAL	18
4.2	TANK CARS	18
4.3	CARGO TANK MOTOR VEHICLES	20
4.4	PORTABLE TANKS.....	21
4.5	TANK BARGES	21
5.	EMERGENCY MEASURES	21
5.1	GENERAL	21
5.2	RESPONSE TO A CHLORINE RELEASE	21
5.3	RESPONSE TO A FIRE.....	22
5.4	RELEASES.....	23
5.5	TRANSPORTATION EMERGENCIES	24
5.6	CHLORINE LEAK AT A CONSUMING LOCATION	26
5.7	ABSORPTION SYSTEMS.....	26
5.8	EMERGENCY KITS AND RECOVERY VESSELS	26
5.9	REPORTING.....	29
6.	EMPLOYEE TRAINING AND SAFETY.....	29
6.1	EMPLOYEE TRAINING	29
6.2	PERSONAL PROTECTIVE EQUIPMENT.....	30
6.3	CONFINED SPACE ENTRY.....	30
6.4	PERSONAL EXPOSURE MONITORING	31

7.	MEDICAL ASPECTS AND FIRST AID	31
7.1	HAZARDS TO HEALTH.....	31
7.2	FIRST AID.....	33
7.3	MEDICAL SURVEILLANCE.....	35
8.	ENGINEERING DESIGN AND MAINTENANCE.....	35
8.1	STRUCTURES	35
8.2	VENTILATION	35
8.3	MATERIAL FOR PROCESSING EQUIPMENT	36
8.4	VAPORIZERS.....	37
8.5	SUPPORT EQUIPMENT.....	37
8.6	PIPING SYSTEMS FOR DRY CHLORINE	38
8.7	PIPING SYSTEMS FOR WET CHLORINE.....	41
8.8	STATIONARY STORAGE	41
8.9	EQUIPMENT MAINTENANCE	41
8.10	CHLORINE NEUTRALIZATION.....	42
9.	U.S. REGULATIONS AND CODES	42
9.1	OCCUPATIONAL SAFETY AND HEALTH REGULATIONS -29 CFR	42
9.2	NAVIGATION AND NAVIGABLE WATER REGULATIONS -33 CFR.....	42
9.3	ENVIRONMENTAL REGULATIONS - 40 CFR.....	42
9.4	SHIPPING REGULATIONS - 46 CFR	43
9.5	TRANSPORTATION REGULATIONS - 49 CFR	43
9.6	DEPARTMENT OF HOMELAND SECURITY – 6 CFR	43
9.7	FIRE CODES	43
10.	TECHNICAL DATA	43
10.1	GENERAL	43
10.2	ATOMIC AND MOLECULAR PROPERTIES	43
10.3	CHEMICAL PROPERTIES	43
10.4	PHYSICAL PROPERTIES.....	47
11.	REFERENCES	54
11.1	CHLORINE INSTITUTE REFERENCES.....	54
11.2	U.S. GOVERNMENT REGULATIONS AND SPECIFICATIONS.....	55
11.3	CANADIAN REGULATIONS	55
11.4	AMERICAN CONFERENCE OF GOVERNMENTAL INDUSTRIAL HYGIENISTS (ACGIH)	56
11.5	AMERICAN SOCIETY OF MECHANICAL ENGINEERS (ASME)	56
11.6	ASTM INTERNATIONAL (ASTM)	56
11.7	COMPRESSED GAS ASSOCIATION (CGA).....	56
11.8	NATIONAL ACADEMY OF SCIENCES (NAS)	57
11.9	NATIONAL FIRE PROTECTION ASSOCIATION (NFPA)	57
11.10	NATIONAL INSTITUTE OF OCCUPATIONAL SAFETY AND HEALTH (NIOSH).....	57
11.11	NSF INTERNATIONAL	57
11.12	U.S. PHARMACOPEIAL CONVENTION	57
	CHLORINE: THE ESSENTIAL ELEMENT	58
	PRODUCTS OF CHLORINE CHEMISTRY	58
	DRAWINGS	59
	DRAWING 122-2: TON CONTAINER LIFTING BEAM.....	60
	DRAWING 183-3: MANIFOLDING TON CONTAINERS FOR LIQUID CHLORINE WITHDRAWAL.....	61
	DRAWING 189-2: CLOSED YOKE CHLORINE CONTAINER VALVE	62

1. INTRODUCTION

1.1 CHLORINE BASICS

The first Chlorine Manual was published by The Chlorine Institute in 1947. It was a comprehensive compilation of information to assist chlorine producers, packagers, and end users in the safe handling, storage, shipment, and use of chlorine. In the years since the original Chlorine Manual was published, the Institute has developed numerous documents that provide more detailed information on safe chlorine management.

With Edition 7 of Pamphlet 1 (2008), the Chlorine Manual was renamed Chlorine Basics. This change reflected the fact that a single document could no longer adequately communicate the detailed information required to safely handle, store, transport, and use chlorine. This pamphlet remains a valued resource, providing basic information for general users and providing an overview and references to more detailed information in other publications available from The Chlorine Institute.

The principal target audiences for this pamphlet are:

- Operations personnel – this is a primary resource document for this group, especially in small companies
- Engineering personnel – this is a roadmap to more detailed information in other pamphlets
- New employees – this is a good “primer” for new employee training and orientation, where the needs are the same as for operations personnel
- Users of Chlorine Institute Emergency Kits A, B, and C (since this document is included in each Kit) – the needs are the same as for operations personnel

For more detailed information, an online catalog is available on the Chlorine Institute’s website – www.chlorineinstitute.org.

1.2 CHLORINE INSTITUTE STEWARDSHIP PROGRAM

The Chlorine Institute (CI) exists to support the chlor-alkali industry and serve the public by fostering continuous improvements to safety and the protection of human health and the environment connected with the production, distribution, and use of chlorine, sodium and potassium hydroxides, and sodium hypochlorite; and the distribution and use of hydrogen chloride. This support extends to giving continued attention to the security of chlorine handling operations.

Chlorine Institute members are committed to adopting CI safety and stewardship initiatives including pamphlets, checklists, and incident sharing that will assist members in achieving measurable improvement. For more information on CI’s stewardship program visit the CI website at www.chlorineinstitute.org.

API	American Petroleum Institute
ASME	American Society of Mechanical Engineers
ASTM	American Society for Testing and Materials, now referred to as ASTM International
CAS	Chemical Abstracts Service
CFR	Code of Federal Regulations
CI	The Chlorine Institute
DHS	U.S. Department of Homeland Security
DOT	U.S. Department of Transportation
EPA	U.S. Environmental Protection Agency
IMDG	International Maritime Dangerous Goods
kPa	Kilopascal
NFPA	National Fire Protection Association
NIOSH	National Institute for Occupational Safety and Health
OSHA	Occupational Safety and Health Administration
ppm	Parts per million
psia	Pounds per square inch, absolute pressure
psig	Pounds per square inch, gauge pressure
PSM	Process Safety Management
RMP	Risk Management Plan

SDS	Safety Data Sheet (Material Safety Data Sheet)
TC	Transport Canada
TEMA	Tubular Exchanger Manufacturers Association, Inc.
TLV	Threshold Limit Value

2. GENERAL INFORMATION

2.1 WHAT IS CHLORINE?

Chlorine is one of 90 natural elements, the basic building blocks of our world. Since it is highly reactive, it is usually found chemically bonded to other elements. Sodium chloride, or common table salt, is one example.

Chlorine plays a vital role in many key uses and applications:

- Chlorine is used to control bacteria and viruses in drinking water that can cause devastating illnesses such as cholera and typhoid. Approximately 98% of modern drinking water systems in the U.S. use chlorine chemistry to ensure the drinking water remains safe from bacterial contamination.
- 93% of all pharmaceuticals rely on chlorine chemistry, including medicines that treat heart disease, cancer, AIDS, and many other life-threatening diseases.
- Chlorine chemistry is involved in the production of over 86% of crop protection chemicals.
- Chlorine is used to produce polyvinyl chloride (PVC) and other plastics. These plastics are used in many diverse products that you use every day.
- The chlorine industry contributes more than \$46 billion to the North American economy annually and helps provide thousands of essential products.

2.2 CHLORINE MANUFACTURE

Most chlorine is manufactured electrolytically by the diaphragm, membrane, or mercury cell process. The use of mercury cell technology is declining. Any new or updated production facility will most likely use the membrane process. In each process, a salt solution (sodium or potassium chloride) is electrolyzed by the action of direct electric current which converts chloride ions to elemental chlorine. Chlorine is also produced in a number of other ways, for example, by electrolysis of molten sodium or magnesium chloride to make elemental sodium or magnesium metal; by electrolysis of hydrochloric acid; and by non-electrolytic processes. Euro Chlor (www.eurochlor.org) has a very detailed animated production process description that can be found at <http://eurochlor.org/the-chlorine-universe/how-is-chlorine-produced.aspx>.

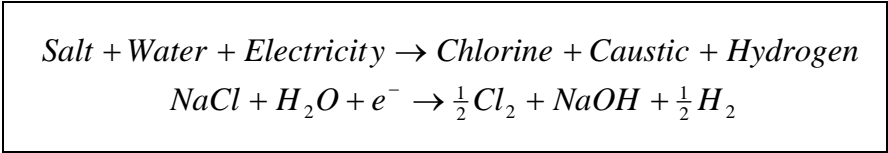

Figure 2.1. Basic Chlor-Alkali Chemical Reaction Equation

Chlorine production for 2012 is estimated to be as follows:

Table 2.1 Chlorine Production	
Area	Million Short Tons
Globally	69
United States	11.4
Canada	0.6
Mexico	0.3

2.2.1 Diaphragm Cell Technology

Currently in North America, a large percentage of chlorine production is from diaphragm cell technology (Fig. 2.2). The products of this type of cell are chlorine gas, hydrogen gas, and cell liquor composed of sodium hydroxide and sodium chloride solution.

A nearly saturated sodium chloride solution (brine) enters the diaphragm cell anode compartment and flows through the diaphragm to the cathode section. Chloride ions are oxidized at the anode to produce chlorine gas. Hydrogen gas and hydroxide ions are produced at the cathode. Sodium ions migrate across the diaphragm from the anode compartment to the cathode side to produce cell liquor containing 10% to 12% sodium hydroxide. Some chloride ions also migrate across the diaphragm resulting in the cell liquor containing 12 - 16% sodium chloride. The cell liquor is typically concentrated to 50% sodium hydroxide by an evaporation process. The salt recovered in the evaporation process is returned to the brine system for reuse.

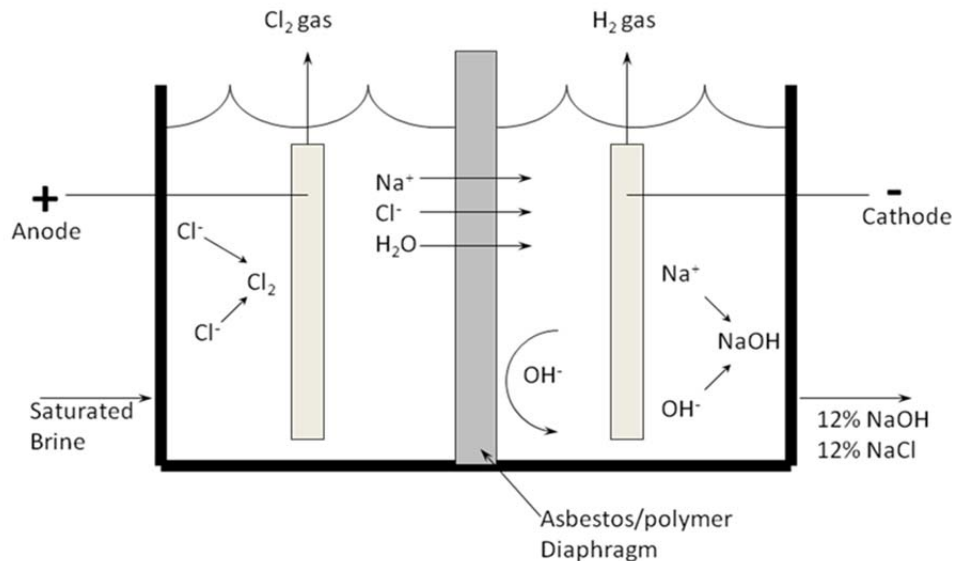

Figure 2.2 – Diaphragm Cell Technology

2.2.2 Membrane Cell Technology

Membrane cell technology (Fig. 2.3) uses sheets of perfluorinated polymer ion exchange membranes to separate the anodes and cathodes within the electrolyzer. Ultra-pure brine is fed to the anode compartments, where chloride ions are oxidized to form chlorine gas. The membranes are cation selective resulting in predominantly sodium ions and water migrating across the membranes to the cathode compartments. Water is reduced to form hydrogen gas and hydroxide ions at the cathodes. In the cathode compartment, hydroxide ions and sodium ions combine to form sodium hydroxide.

Membrane electrolyzers typically produce 30% to 35% sodium hydroxide, containing less than 100 ppm of sodium chloride. The sodium hydroxide can be concentrated further, typically to 50%, using evaporators.

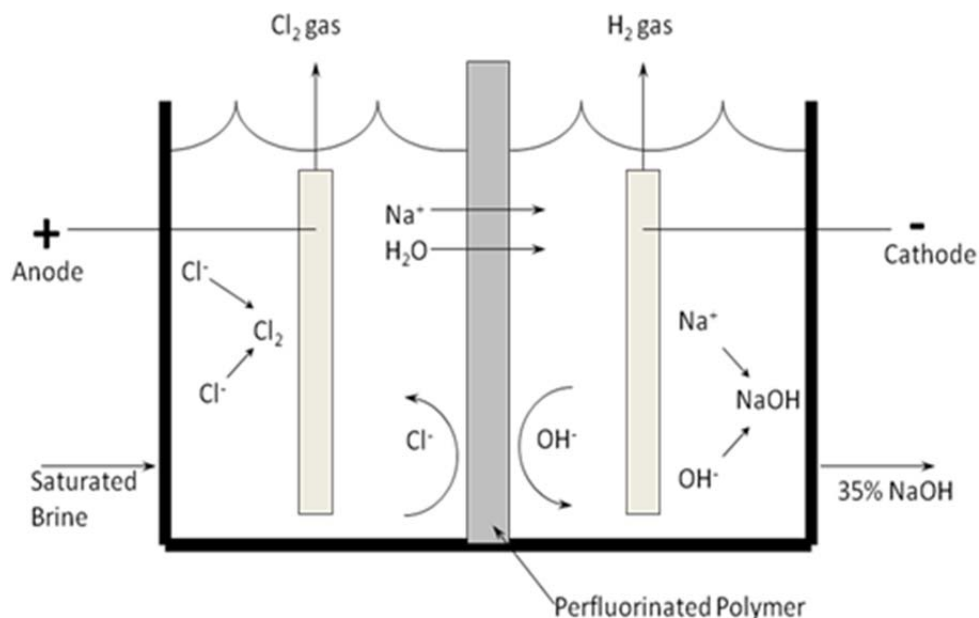

Figure 2.3 Membrane Cell Technology

2.2.3 Mercury Cell Technology

Mercury cell technology (Fig. 2.4) uses a stream of mercury flowing along the bottom of the electrolyzer as the cathode. The anodes are suspended parallel to the base of the cell, a few millimeters above the flowing mercury. Brine is fed into one end of the cell box and flows by gravity between the anodes and the cathode. Chlorine gas is evolved and released at the anode.

The sodium ions are deposited along the surface of the flowing mercury cathode. The alkali metal dissolves in the mercury, forming a liquid amalgam. The amalgam flows by gravity from the electrolyzer to the carbon-filled decomposer, where deionized water is added. The water chemically strips the alkali metal from the mercury, producing hydrogen and 50% sodium hydroxide. The mercury is then pumped back to the cell inlet, where the electrolysis process is repeated.

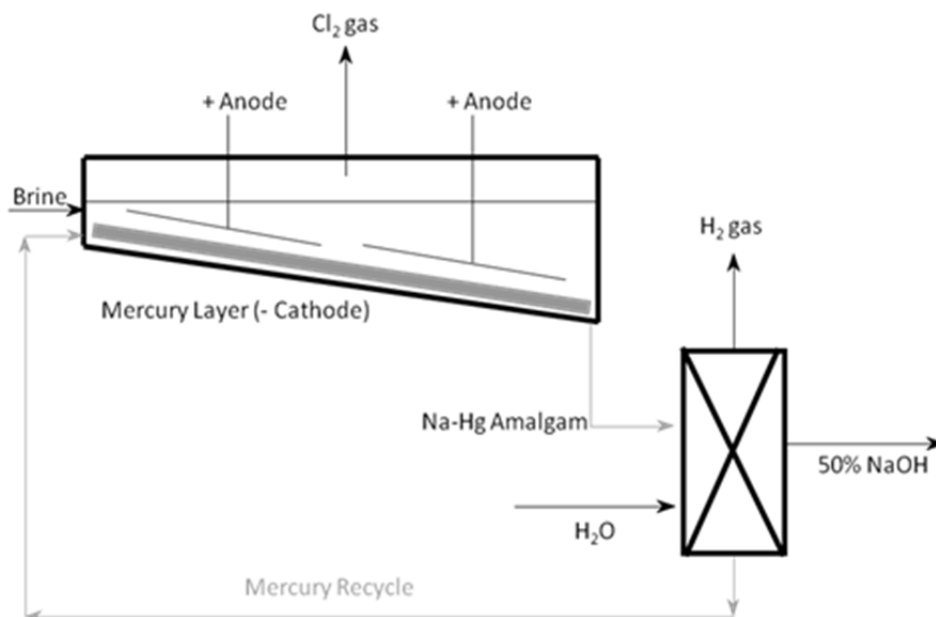

Figure 2.4 – Mercury Cell Technology

2.3 CHLORINE TRANSPORTATION

2.3.1 General

Chlorine is normally shipped as a liquefied compressed gas. The transportation of chlorine by all modes is controlled by various regulations. It is the responsibility of each person shipping or transporting chlorine to know and to comply with all applicable regulations.

2.4 OTHER REGULATORY ASPECTS

Chlorine manufacturers, packagers, and most consumers are subject to workplace regulations pertaining to chlorine.

2.4.1 United States

There are many regulations at the federal, state, and local levels that apply to chlorine manufacture, transport, and use. Agencies such as OSHA, EPA, DOT, and DHS regulate various aspects of the chlorine industry and should be consulted. Refer to Section 9 of this pamphlet for more information.

Table 2.2 Chlorine Classification

Country	Hazard Class	Division	Key Regulation	Other
United States	Primary: 2	Primary: 2.3 Poison Gas	Land: 49 CFR Barge: 33 CFR and 46 CFR	Poison Zone B inhalation hazard material rating.
	Secondary: 5, 8	Secondary: 5.1 Oxidizer		
Canada	Primary: 2	Primary: 2.3 Poison Gas	Transportation of Dangerous Goods Act and Regulations (TDG)	Various provincial and/or local regulations
	Secondary: 5	Secondary: 5.1 Oxidizer		
Mexico	Primary: 2	Primary: 2.3 Poison Gas	Regulation for Surface Transportation of Hazardous Materials and Waste	Various state and/or local regulations.
	Secondary: 5	Secondary: 5.1 Oxidizer		
International			International Maritime Dangerous Goods Code (IMDG)	Designation for chlorine: UN1017

2.4.2 Canada

There are many regulations at the federal, provincial, and local levels that apply to chlorine manufacture, transport, and use. Agencies such as Health Canada, Environment Canada, and Transport Canada regulate various aspects of the chlorine industry and should be consulted.

2.5 TERMINOLOGY

2.5.1 Elemental Chlorine

Chlorine's symbol is Cl, its atomic number is 17, and its atomic weight is 35.453. Elemental chlorine almost always exists as a molecule with two chlorine atoms bound together as Cl₂. Its molecular weight is 70.906. The CAS registry number is 7782-50-5.

2.5.2 Liquid Chlorine

Liquid chlorine is chlorine (Cl_2) which has been cooled and compressed to a liquid form. Under atmospheric temperature and pressure, liquid chlorine evaporates quickly, with one pound of liquid forming about 5.4 cubic feet of chlorine gas.

Liquid chlorine is NOT the same as a hypochlorite or chlorine bleach solutions and this terminology should not be used to describe such solutions.

2.5.3 Chlorine Gas

At atmospheric conditions, chlorine is a gas.

2.5.4 Dry Chlorine/Wet Chlorine

Dry chlorine is defined as chlorine with its water content dissolved in solution. If a condition is reached anywhere in the system that will allow the water to exceed its solubility and form a second aqueous liquid phase, the chlorine is defined as wet chlorine. Wet chlorine will form corrosive compounds affecting the safety and integrity of the system. See CI Pamphlet 100 (11.1).

Dry Chlorine is NOT a dry chlorinating compound such as calcium hypochlorite or chloroisocyanurates and this terminology should not be used to describe such a substance.

2.5.5 Moist Chlorine

Synonymous with wet chlorine.

2.5.6 Saturated Chlorine Gas

Chlorine gas in such condition that the removal of any heat or an increase in pressure will cause some portion of it to condense to a liquid. This term does not describe or refer to the relative moisture content of the chlorine.

2.5.7 Saturated Chlorine Liquid

Chlorine liquid in such condition that the addition of any heat or a decrease in pressure will cause some portion of the chlorine to vaporize to a gas. This term does not describe or refer to the relative moisture content of the chlorine.

2.5.8 Chlorine Solution (Chlorine Water)

A solution of chlorine in water (see Figure 10.3).

A chlorine solution is NOT the same as hypochlorite or chlorine bleach solutions and this terminology should not be used to describe such solutions.

2.5.9 Liquid Bleach

An aqueous solution of hypochlorite, usually sodium hypochlorite (NaOCl).

2.5.10 Container

In this publication, a container is a pressure vessel authorized by an applicable regulatory body for the transport of chlorine. It does not include pipelines or stationary storage tanks.

2.5.11 Filling Density

By DOT and TC regulation, the weight of chlorine that is loaded into a container may not exceed 125% of the weight of water at 60°F (15.6°C) that the container will hold.

2.5.12 Sodium Hydroxide

Normally sodium hydroxide (NaOH) is the co-product produced as a solution when chlorine is generated through the electrolytic decomposition of sodium chloride solution. Sodium hydroxide is frequently referred to as caustic soda or lye.

2.5.13 Potassium Hydroxide

A co-product produced as a solution when chlorine is generated through the electrolytic decomposition of potassium chloride salt solution. Potassium hydroxide (KOH) is frequently referred to as caustic potash.

2.6 SPECIFIC MANUFACTURING AND USE HAZARDS

Refer to your supplier's Safety Data Sheet (SDS) and referenced CI pamphlets for additional safety and handling precautions.

2.6.1 Hydrogen

Hydrogen (H₂) is a co-product of all chlorine manufactured by the electrolysis of aqueous brine solutions. Within a known concentration range, mixtures of chlorine and hydrogen are flammable and potentially explosive. The reaction of chlorine and hydrogen can be initiated by direct sunlight, other sources of ultraviolet light, static electricity, or sharp impact. See CI Pamphlet 121 (11.1).

2.6.2 Nitrogen Trichloride

Small quantities of nitrogen trichloride (NCl₃), an unstable and highly explosive compound, can be produced in the manufacture of chlorine. When liquid chlorine containing nitrogen trichloride is evaporated, the nitrogen trichloride may concentrate to hazardous concentrations in the residue (see CI Pamphlets 21 and 152 (11.1)).

2.6.3 Oils and Grease

Chlorine can react, at times explosively, with a number of organic materials such as oil and grease from sources such as air compressors, valves, pumps, oil-diaphragm instrumentation, pipe thread lubricants. Equipment and piping must be cleaned prior to use to remove any oils. See CI Pamphlet 6 (11.1). Ensure that non-reactive lubricants are used in chlorine service (e.g. Fluorolube® and Krytox®).

2.6.4 Fire

Chlorine is neither explosive nor flammable. Chlorine will support combustion under certain conditions. Many materials that burn in oxygen (air) atmospheres will also burn in chlorine atmospheres.

2.6.5 Chemical Action/Reactions

Chlorine has a very strong chemical affinity for many substances. It will react with many inorganic and organic compounds, usually with the evolution of heat. Chlorine reacts with some metals under a variety of conditions (see Section 10.3.3). It is especially important to not use any titanium in dry chlorine service. Chlorine will react with steel and other metals at temperatures above 149°C (300°F). Do not weld piping and other equipment without properly evacuating and purging chlorine from the equipment.

2.6.6 Corrosive Action on Steel and Other Metals

At ambient temperatures, dry chlorine, either liquid or gas, does not corrode steel. Wet chlorine is highly corrosive because it forms hydrochloric and hypochlorous acids. Precautions should be taken to keep chlorine and chlorine equipment dry. Piping, valves, and containers should be closed or capped when not in use to keep out atmospheric moisture such as precipitation or humidity. Materials of construction must be chosen carefully, depending on the conditions that are expected. If water is used on a chlorine leak, the resulting corrosive conditions will make the leak worse.

2.6.7 Volumetric Expansion

The volume of liquid chlorine increases with temperature. Precautions should be taken to avoid hydrostatic rupture of piping, vessels, containers, or other equipment filled with liquid chlorine (see Figure 10.4). Any time liquid chlorine can be trapped between two valves, an expansion device should be present.

2.6.8 Personal Protection

The most significant health hazard associated with chlorine is being exposed to chlorine vapors. Respiratory protection must be assured by process design, operating procedures and personal protective equipment. Skin contact with liquid chlorine can result in frostbite. See CI Pamphlet 65 (11.1).

3. CYLINDERS AND TON CONTAINERS

3.1 CONTAINER DESCRIPTIONS

3.1.1 General

Cylinders and ton containers have many similarities in the way in which they are handled. The terms “cylinder,” “ton cylinder,” or “drum” should not be used to describe the ton container. Emergency and other equipment for handling ton containers is different from that used for cylinders and confusion can be avoided if the proper terms are used.

In this document, "container" will be used to refer to any vessel that holds chlorine for the purpose of transporting the product. This may include cylinders, ton-containers, cargo tanks, tank cars, and barges. If the information provided is specific to the type of container, it will be specified.

Site chlorine inventories exceeding the threshold quantity are subject to regulations such as RMP and PSM. Check with federal, state, and provincial agencies for threshold requirements.

3.1.2 Cylinders

Chlorine cylinders are of seamless construction with a capacity of 1 to 150 lb (0.45 to 68 kg); those of 100 and 150 lb (45.4 and 68 kg) capacity predominate. The only opening in the cylinder is the valve connection at the top of the cylinder. The steel valve protective housing should be utilized to cover the valve during shipment and storage. Care must be taken with the protective cap since the cylinder neck-ring to which it is attached is not physically welded to the cylinder.

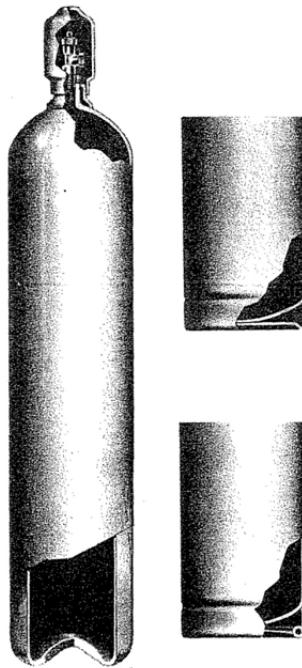

Figure 3.1 – Chlorine Cylinder
(Left – bump-bottom; Upper right – double-bottom; Lower right - foot ring)

3.1.3 Ton Containers

Ton containers are welded tanks having a capacity of one short ton, 2000 lb (907 kg), and a loaded weight of as much as 3650 lb (1655 kg). The sides are crimped inward at each end to form chimes which provide a substantial grip for lifting beams. The ton container valves are protected by a removable steel valve protective housing.

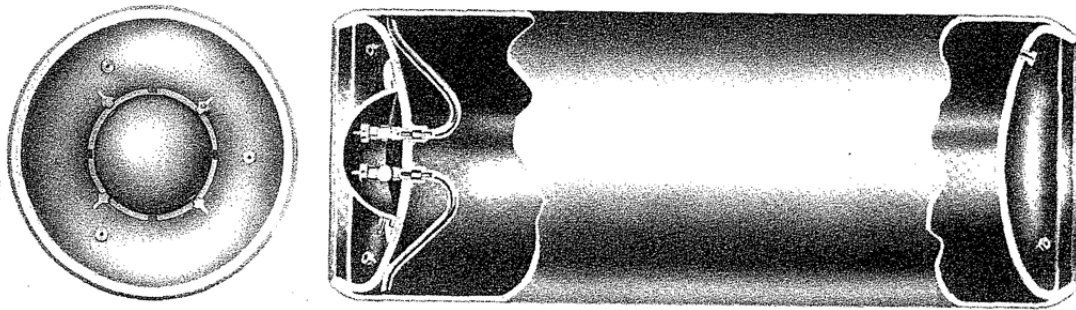

Figure 3.2 – Chlorine Ton Container

3.2 CONTAINER VALVES

3.2.1 Cylinder Valves

The typical cylinder is equipped with one valve. The valve outlet threads are not standard pipe threads, but are special straight threads. These outlet threads are intended for securing the valve outlet cap and not for connecting unloading connections or other devices. Typical cylinder connections are made with a yoke and adapter. See CI Pamphlet 17 (11.1). The valve is also equipped with a fusible metal pressure relief device or, as more commonly named, a fusible plug.

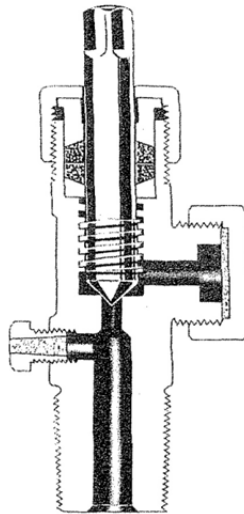

Figure 3.3 – One Typical Style of a Cylinder Valve (Other designs may also be in use)

3.2.2 Ton Container Valves

Each ton container is equipped with two identical valves near the center of one end. They are different from the typical cylinder valve in that they have no fusible metal plug and usually have a larger internal passage. Each valve connects to an internal education tube. See CI Pamphlet 17 (11.1).

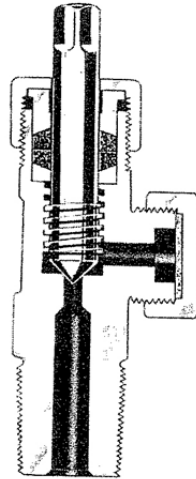

Figure 3.4 – One Style of a Chlorine Ton Container Valve (Other designs may also be in use)

3.3 PRESSURE RELIEF DEVICES

3.3.1 General

Cylinders and ton containers are equipped with a metal relief device or fusible plug. The fusible metal is designed to comply with the requirements of 49 CFR Part 173.301(f), and therefore, will melt between 158°F and 165°F (70°C and 74°C). These devices will relieve pressure when subjected to temperatures at or above the melting point of the fusible metal. The devices will not function in the absence of high temperature.

3.3.2 Cylinders

Cylinder valves are equipped with one fusible metal relief device or fusible plug.

3.3.3 Ton Containers

Ton containers are equipped with fusible metal pressure relief devices. Most have six fusible metal plugs, three in each end.

3.4 CONTAINER SHIPPING

3.4.1 Cylinders

Cylinders may be shipped by highway, rail, or water. Suitable restraints are necessary to prevent cylinders from shifting during transportation. See CI Pamphlet 76 (11.1).

3.4.2 Ton Containers

Most ton containers are shipped by highway. Trucks must have suitable hold-down devices to prevent the ton containers from shifting during transportation. Trucks are sometimes equipped with a crane and lifting beam to facilitate loading and unloading. See CI Pamphlet 76 (11.1).

3.5 CONTAINER MARKING/LABELING AND VEHICLE PLACARDING

Containers in transportation must be marked and labeled and the vehicle placarded as required by regulations.

3.6 CONTAINER HANDLING

3.6.1 General

Chlorine containers must be handled with care. During shipment and storage, container valve protective housings should be in place. Containers should not be dropped and no object should be allowed to strike them with force. Containers should be secured to prevent them from rolling. See CI Pamphlet 76 (11.1).

3.6.2 Cylinders

Cylinders can be moved using a properly balanced hand truck. The hand truck should have a clamp or chain two-thirds of the way up the cylinder wall to hold the cylinder in place. If cylinders must be elevated by hoist, a specially designed cradle or carrier should be used. Slings and magnetic devices are unacceptable. Cylinders must not be lifted by the valve protective housing because the neck-ring to which the housing is attached is not designed to carry the weight of the cylinder.

3.6.3 Ton Containers

Ton containers are typically moved using a monorail or crane with a lifting beam (see Drawing 122). They can be rolled on rails or roller conveyors designed for this purpose. If a forklift truck is used, the ton container must be adequately restrained to prevent it from falling off, particularly when the truck changes direction. The forklift truck must be rated to handle the gross weight of the ton container.

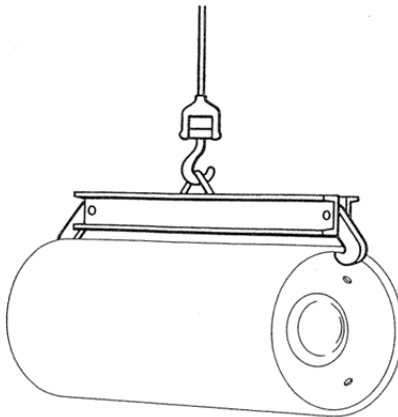

Figure 3.5 – Lifting Beam for Handling Chlorine Ton Containers

3.7 CONTAINER STORAGE

Containers may be stored indoors or outdoors. The storage area should comply with federal and state regulations.

If stored outdoors, the storage area should be clean so that accumulated trash or other combustible material does not present a fire hazard. Containers should not be stored near elevators or ventilating systems because dangerous concentrations of gas may spread rapidly if a leak occurs. All containers should be stored to minimize external corrosion.

Exposure of containers to flame, intense radiant heat or to steam lines must be avoided. If the metal in the vicinity of the fusible plug reaches approximately 158°F (70°C), the fusible metal plug is designed to melt and chlorine will be released.

See CI Pamphlets 17 and 155 (11.1) for more detail on storage considerations.

3.8 CONTAINER USE

3.8.1 General

Before connecting or disconnecting a container, the operator should make sure that all safety and emergency equipment is available and operable. Containers and valves must not be modified, altered, or repaired by anyone other than the owner.

3.8.2 Gas Discharge

Chlorine gas discharge rates vary significantly because of local ambient temperature, humidity and air circulation, as well as the variations in the piping system and feeding equipment connected to the container. See CI Pamphlet 155 for details (11.1).

If the gas discharge rate from a single container will not meet the flow requirements, two or more may be connected to a manifold. Alternately, liquid from one or more containers may be sent to a vaporizer for increasing the chlorine gas delivery rate (see Section 3.8.3).

When discharging through a gas manifold, all containers should be at the same temperature to prevent transfer of gas from a warm container to a cool container.

3.8.3 Liquid Discharge

Discharging liquid chlorine has special design requirements. See CI Pamphlet 6 (11.1).

Liquid chlorine is delivered from the lower valve of a ton container. See the picture of eductor tubes in Figure 3.2. Very high liquid withdrawal rates can be obtained. The rate depends on the temperature of the chlorine in the ton container and on the backpressure. The dependable continuous discharge rate of liquid chlorine under normal temperature conditions and against a pressure of 35 psig (241 kPa gauge) is at least 400 lb/hr (181 kg/hr) for ton containers. When connected to a manifold, ton containers discharging liquid chlorine should include precautions to equalize the pressure. Drawing 183 depicts a system for equalizing pressures for gas valves

connected to a manifold. It is not sufficient to depend on ton containers reaching the same pressure merely by storing them in the same working area. Piping evacuation procedures should be established so liquid chlorine is not trapped in the system.

3.8.4 Weighing

Because chlorine is shipped as a compressed liquefied gas, the pressure in a container depends on the temperature of the chlorine (Figure 10.1). The pressure is not related to the amount of chlorine in the container. Container contents can be determined accurately only by weighing.

3.8.5 Connections

A chlorine compatible flexible connection must be used between the container and a pressurized piping system. Copper tubing with a diameter of 1/4-inch or 3/8-inch is recommended. Flexible metallic hoses or fluoroplastic hoses as described in CI Pamphlet 6 (11.1) are also acceptable materials. If a system is to remain in operation while containers are being connected or disconnected, auxiliary (isolating) container valves must be used. Flexible connections should be inspected and replaced on a regular basis. A flat gasket on the face of the valve is part of the connection. A new gasket should be used each time a connection is made (see CI Pamphlets 6 and 155 (11.1) and Drawing 189).

3.8.6 Opening Valves

The container valve is opened by turning the valve stem in a counter-clockwise direction. One full turn of the stem typically permits an appropriate feed rate. More stem turns should not be made unless recommended by the supplier. A wrench (50 ft/lbs maximum torque), no longer than 8 inches, should be used. Never use a wrench extension (cheater bar) as the valve may be damaged preventing gas-tight shutoff. Once the valve is opened, the wrench should be left in place so that the valve can be closed quickly. Do not loosen the packing nut unless authorized by the supplier.

To connect a line to the container, ensure the valve is closed. Make certain that the packing nut is at least hand tight; if it is not, contact your supplier for advice. Remove the valve outlet cap and attach the line to the valve with a yoke. Use a new gasket each time a connection is made. Make sure connections are tight.

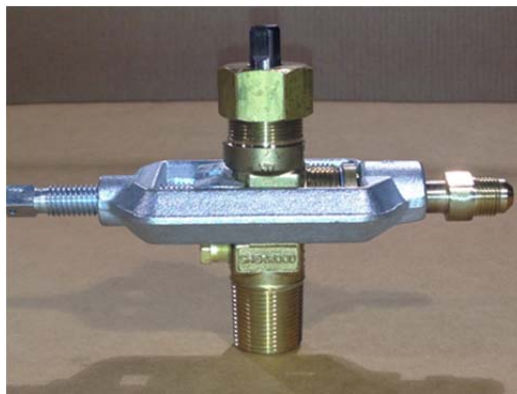

Figure 3.6 – Open Yoke Adapter – Type Connector

Once connections have been made, pressurize the system with a small amount of chlorine, and check for leaks. If a leak is found, it must be remedied before proceeding (see CI Pamphlet 155 (11.1)).

3.8.7 Closing Valves

Apply 25-30 foot-pounds to the valve stem. Check for leaks. If any leaks still exist, the torque may be increased up to 40 foot-pounds. If the leak has not stopped at 40 foot-pounds, increase the torque on the valve stem to 50 foot-pounds. Foreign objects such as rust flakes or other debris can prevent positive shutoff of chlorine valves. If the container remains connected to the process and it is safe to do so, a complete cycling of the valve may dislodge the foreign material and allow positive valve shutoff. Always verify the valve is being turned clockwise for closing. If this fails to work, contact your supplier.

3.8.8 Disconnecting Containers

As soon as a container is empty, the valve should be closed (see Section 3.7.7). Prior to disconnecting, reconfirm that the valve is closed and provide a means of removing the chlorine trapped in the flexible connecting line. This can be accomplished by either purging the line with dry air or nitrogen with a dew point of -40°F (-40°C) or lower or by applying a vacuum. Personal Protective Equipment should be used as appropriate for the task. See CI Pamphlet 65 (11.1). The container should be cautiously disconnected in case residual chlorine remains in the lines. The outlet cap should be applied promptly and the valve protective housing should be replaced. The open end of the disconnected flexible line should be capped promptly to keep atmospheric moisture from entering the system.

4. BULK SHIPPING CONTAINER

4.1 GENERAL

Bulk chlorine is shipped by pipeline, tank cars, tank motor vehicles, portable tanks, and barge tanks.

4.2 TANK CARS

4.2.1 General

The following is generalized information on chlorine tank cars. See CI Pamphlet 66 (11.1).

4.2.2 Specifications

The most commonly used tank cars have a chlorine capacity of 90 tons. By regulation, tank cars may not be loaded with chlorine in excess of the nominal weight.

Table 4.1 Key Government Specifications

United States	49 CFR 179.102-2	49 CFR 176-314 (c) note 12
Transport Canada	79.102-2	73.314 (c) note 12

The regulations require tank cars to be equipped with a pressure relief device whose setting is stenciled on the side of the car. Tank cars must be thermally protected with four inches of insulating material.

4.2.3 Manway Arrangement

The only opening into a chlorine tank car is through a manway on top, where the valves are enclosed with a steel cover.

Most chlorine tank cars have four angle valves. They also have one pressure relief device designed to release excess pressure buildup within the tank. Two of the angle valves are located on the longitudinal center of the car. These valves are connected to eduction pipes that run to the bottom of the tank and are used to unload liquid chlorine. Two angle valves are located on a line perpendicular to the car's length and are connected to the vapor phase. These valves should never be used for gas withdrawal, but can be used to pressurize the car when needed to increase the rate of liquid withdrawal. In cars built prior to 2009, the liquid valves are equipped with excess flow valves designed to close at flow rates of 7,000, 15,000 or 32,000 lb per hour. The flow rate is usually stenciled on the side of the car. Unstenciled cars have 7,000-lb-per-hour valves.

Starting in 2009, chlorine tank cars began to be equipped with an alternate valve design. The primary feature that is different on the alternate design is that a check valve is used in place of an excess flow valve. The check valve is designed to remain closed during transport, so in the unlikely event of a rollover where valves shear off, the valve port remains closed and prevents an accidental release. Arrangements consisting of the alternate design may have wider bases and can consist of either 3 or 4 liquid/vapor valves and one pressure relief device.

The CI Emergency Kit C is designed to be used for stopping leaks on chlorine tank cars. See CI Pamphlet 66 (11.1). It is important to know if an alternate valve design or the traditional valve design is used on a tank car because the C-Kit will need to be applied differently, depending on the valve design encountered.

For additional guidelines, recommended practices, and other useful information concerning chlorine tank cars, refer to CI Pamphlets 66, 166 and 168 (11.1).

4.2.4 Transfer Operations

The following is general information. See CI Pamphlet 66 (11.1).

Precautions

Every site handling chlorine in bulk containers should have RMP and PSM programs.

Special attention should be directed to the appropriateness of emergency procedures and to equipment to be used in an emergency.

Chlorine transfer operations must be performed only by personnel who are trained as required by applicable hazardous material regulations.

DOT (49 CFR), OSHA (29 CFR) and TC (Sec. 10.2) have specific training requirements applicable to handling of hazardous materials.

All personnel responsible for transfer operations should be knowledgeable about the facility's emergency response plan for handling spills and leaks of products. See CI Pamphlet 66 (11.1).

Before beginning transfer operations, a number of things should be considered. Details can be found in CI Pamphlet 66. A partial list of topics includes:

- Connections
- Pressure padding
- Monitoring
- Disconnecting

4.3 CARGO TANK MOTOR VEHICLES

4.3.1 General

The following is generalized information on chlorine cargo tank motor vehicles. See CI Pamphlet 49 (11.1). In North America, they usually have a capacity ranging from 15 to 22 tons (13,600 kg to 20,000 kg) with certain exceptions. DOT specifications apply only to the tank.

4.3.2 Manway Arrangement

The manway arrangement is the same as that on chlorine tank cars (see Section 4.2.3) except that special excess-flow valves are required under the gas valves.

4.3.3 Transfer Operations

Procedures for transferring chlorine to/from cargo tanks are essentially the same as for tank cars. There is, however, more variation in facilities and conditions at customers' plants, and these may require modifications of methods and equipment.

4.3.4 Precautions

The engine should be shut off, hand brakes must be set, and wheel chocks must be in place during transfer. The tank motor vehicle must be attended at all times. The tank motor vehicle must not be moved when loading or unloading connections are attached to the vehicle (see discussion of tank car transfer, Section 4.2.40, for additional, applicable precautions).

4.3.5 Emergency Equipment

Approved respiratory equipment is required on the transport vehicle. An Emergency Kit "C" must be on the transport vehicle. Proper training on the use of emergency equipment is required (OSHA 29 CFR 1910.134).

It also is required that the transport vehicle have 2-way communication such as a cell phone or radio.

4.3.6 Connections/Disconnecting

See discussion for tank cars (Section 4.2.4).

The driver should recheck all equipment by a visual inspection before starting the vehicle.

4.3.7 Pressure Padding

See discussion for tank cars (Section 4.2.4).

4.4 PORTABLE TANKS

Tanks suitable for multi-modal transportation (road, rail, and water) of chlorine should be built under the provisions of DOT 51 and special provisions for chlorine. See CI Pamphlet 49 (11.1).

4.5 TANK BARGES

Consult your supplier for information on chlorine barges.

5. **EMERGENCY MEASURES**

5.1 GENERAL

A chlorine emergency may occur during manufacture, use, or transportation. Trained employees, along with a comprehensive, written emergency response plan are necessary to mitigate the consequences of the emergency. Regular drills and reviews of emergency response plans with all involved organizations are encouraged. See CI Pamphlet 64 (11.1). Federal, state and provincial regulations, as well as various local fire and building codes, regulate chemical emergency preparedness and response. All persons responsible for the handling of chlorine must be familiar with those requirements. Regulatory requirements deal generally with preparation and response to chemical and other emergencies. See CI Pamphlet 64 (11.1). Help is also available from CHLOREP (see Sections 5.5.1 to 5.5.3) which can be accessed through CHEMTREC (U.S.). In Canada, CANUTEC may provide advice, as well as contact information for the appropriate CHLOREP Team.

5.2 RESPONSE TO A CHLORINE RELEASE

As soon as there is any indication of a chlorine release, immediate steps must be taken to correct the condition. Chlorine leaks always get worse if they are not promptly corrected. When a chlorine leak occurs, authorized, trained personnel equipped with respiratory and appropriate other PPE should investigate and take proper action. Personnel should not enter into atmospheres containing concentrations of chlorine in excess of the IDLH Concentration of 10 ppm without appropriate personal protective equipment and backup personnel.

CI Pamphlet 65 (11.1) provides PPE recommendations for responders to a chlorine release. Keep unnecessary personnel away and isolate the hazard area. Persons potentially affected by a chlorine release should be evacuated or sheltered-in-place as circumstances warrant.

Area chlorine monitors and wind direction indicators can supply timely information (e.g., escape routes) to help determine whether personnel are to be evacuated or sheltered in place.

When evacuation is necessary, potentially exposed persons should move to a point upwind of the leak. To escape in the shortest time, persons already in a contaminated area should move crosswind. Because chlorine is heavier than air, higher elevations are preferable.

When inside a building and sheltering-in-place is selected, shelter by closing all windows, doors and other openings, and turning off air conditioners and air intake systems. Personnel should move to the side of the building furthest from the release.

Care must be taken not to position personnel without an escape route. A safe position may be made hazardous by a change in wind direction. New leaks may occur or the existing leak may get larger.

If notification of local authorities is required, the following information should be provided:

- Company name, address, telephone number and the name of the person(s) to contact for further information
- Description of the emergency
- Travel directions to the site
- Type and size of container involved
- Corrective measure being applied
- Other pertinent information, i.e., weather conditions, injuries, etc.

There are specific government requirements for reporting a hazardous chemical release. Releases must be reported in a timely manner. See CI Pamphlet 64 (11.1).

5.3 RESPONSE TO A FIRE

If fire is present or imminent, chlorine containers and equipment should be moved away from the fire, if it is possible to do so safely. If a non-leaking container or equipment cannot be moved, it should be kept cool by applying water on it.

Water should not be used directly on a chlorine leak. Chlorine and water react forming acids and the leak will quickly get worse. However, where several containers are involved and some are leaking, it may be prudent to use a water spray to help cool the non-leaking containers. Whenever containers have been exposed to flames, cooling water should be applied until well after the fire is out and the containers are cooled.

Containers exposed to fire should be isolated and the supplier should be contacted as soon as possible.

5.4 RELEASES

5.4.1 General

Chlorine facilities should be designed and operated so that the risk of a chlorine release into the environment is minimized. However, accidental releases and leaks of chlorine may occur. The overall effects of such releases must be considered.

5.4.2 Detection of Minor Releases and Leaks

A plastic squeeze bottle containing 26° Baumé (30 wt.%) aqua ammonia can be used to detect a minor release or leak. If ammonia vapor is directed at a leak, a white cloud will form indicating the source of the leak. If a wash bottle is used, the dip tube should be cut off so that squeezing the bottle directs vapor, not liquid, out of the nozzle. Avoid contact of aqua ammonia with brass or copper. Portable electronic chlorine monitors can also be used to detect leaks. If a leak occurs from equipment or piping, the chlorine supply should be shut off, the pressure relieved and necessary repairs made.

Leaks around shipping container valve stems usually can be stopped by tightening the packing gland. If such tightening does not stop the leak, the container valve should be closed. Leaks at the packing nut will always stop when the valve is closed. See CI Pamphlet 66 (11.1). If simple corrective measures are not sufficient, the appropriate Chlorine Institute Emergency Kit should be applied or the cylinder should be placed in a recovery vessel designed to contain the leak, and the chlorine supplier notified (see Section 5.8).

5.4.3 Area Affected

The area affected by a chlorine release and the duration of the exposure depend upon the total quantity released, the rate of release, the height of the release point and weather conditions, as well as the physical form of the chlorine being released. These factors are difficult to evaluate in an emergency situation. Chlorine downwind can vary from barely detectable to high concentrations. CI Pamphlet 74 (11.1) provides information on the area affected by specific chlorine release scenarios.

5.4.4 Physical Form of the Chlorine Released

Typically, chlorine is stored and transported as a liquid under pressure. Liquid chlorine expands in volume by nearly 460 times when it vaporizes; therefore, a liquid chlorine leak can have significantly greater downwind effect than a gaseous chlorine leak.

During a release, chlorine can escape as a gas, a liquid, or both. When pressurized liquid or gas is released from a container, the temperature and pressure inside the container will decrease thus reducing the release rate.

5.4.5 Effect of Chlorine on the Environment

Vegetation

Plants in the path of a chlorine release may be damaged. Leaves may be bleached and browning and leaf loss may occur. Healthy plants will usually recover with time.

Animals

Seek medical attention for evaluation or treatment for pets and other animals that experience irritation or any signs of respiratory distress.

Aquatic Life

Chlorine is only slightly soluble in water and there would be little absorption from a cloud of chlorine gas. If chlorine is released into a lake or stream, it may harm aquatic plants and animals until it dissipates.

5.5 TRANSPORTATION EMERGENCIES

DOT and TC require that any person who offers chlorine for transportation must provide a staffed 24-hour emergency response telephone number that can be called in the event of an emergency involving chlorine. The SDS, provided by the chlorine supplier, contains this contact information. This information may also be found on the bill of lading and the shipping container.

5.5.1 CHLOREP

The Chlorine Emergency Plan (CHLOREP) was established in January 1973 by CI as an industry-wide program to improve the speed and effectiveness of response to chlorine emergencies in the United States and Canada.

The primary purpose of the Plan is to minimize the risk of injury arising from the actual or potential release of chlorine during emergencies occurring in the course of transportation at distribution points, or at chlorine user locations. Under this Plan, the United States and Canada have been divided into regional sectors where trained emergency teams from producing, packaging, distribution, and consuming plants are available on a 24-hour basis to handle possible or actual chlorine releases.

5.5.2 CHEMTREC, CANUTEC, & SETIQ

During a chlorine emergency, any carrier, customer, or civil authority can obtain basic emergency information and contact information for the closest chlorine emergency group through CHEMTREC (U.S.), CANUTEC (Canada), SETIQ (Mexico), or their chlorine supplier. The emergency response call center, i.e. CHEMTREC and CANUTEC, provides immediate advice for those at the scene of emergencies. CHEMTREC will promptly contact the appropriate responder group as required. CANUTEC will provide contact information and participate on a call to the appropriate responder, which must be initiated by the incident scene contact. In many cases, the responder will be the shipper. However, in some cases, the designated response group is called and then the shipper is notified.

Table 5.1 Emergency Contact Information

Dispatch Agency	Country	Phone Number
CHEMTREC	Continental United States	1-800-424-9300
CHEMTREC	Alaska and Hawaii	1-703-527-3887
CHEMTREC	Marine radio telephone	1-703-527-3887
CHEMTREC	Collect calls anywhere in the US	1-703-527-3887
CANUTEC	Canada	1-613-996-6666 (collect calls accepted)
SETIQ	Mexico	01-800-00214-00
SETIQ	Mexico – from outside the country	011-55-5-5591588

5.5.3 In-Transit Emergency Response

If a chlorine leak develops in transit, appropriate emergency measures should be taken as quickly as possible.

If a vehicle transporting chlorine cylinders or ton containers is disabled and there is any possibility of fire, the containers should be removed from the vehicle to a safe distance if possible.

If a tank car or cargo tank trailer is disabled and chlorine is leaking, appropriate emergency procedures should be instituted in consultation with local authorities. Clearing of track or highway should not be started until safe working conditions are established. See Section 5.3 for action to take if a fire occurs.

The specific actions taken by emergency responders will vary. Some items to consider acting upon are:

- Is it possible to safely turn the container so that gas instead of liquid escapes? The quantity of chlorine that escapes from a gas leak is much less than the amount that escapes from a liquid leak through the same size hole.
- Is it possible to safely reduce the pressure in the container by removing the chlorine as gas (not as liquid) to a process or a disposal system? (See Sections 5.6 and 5.7).
- Can the container be safely moved to an isolated spot where the consequences can be minimized?
- Is it possible to safely apply the appropriate Chlorine Institute Emergency Kit or place the cylinder in a recovery vessel designed to contain the leak? (See Section 5.8).

A leaking chlorine container must not be immersed or thrown into a body of water; the leak will be aggravated and the container may float when still partially full of liquid chlorine allowing gas evolution at the surface.

Specific government regulations must be followed for the shipment of a leaking chlorine container or a container which has been exposed to fire, whether full or partially full. In such cases, special arrangements are required and the chlorine supplier should be consulted first.

5.6 CHLORINE LEAK AT A CONSUMING LOCATION

In addition to leak mitigation efforts, the following may be considered:

- It may be best to consume the chlorine through the regular process. If the consuming process cannot handle chlorine under emergency conditions, a standby alkali absorption system or a scrubber should be considered.
- It must be recognized that systems consuming liquid chlorine at low rates may not significantly reduce pressure in the supply container. In order to reduce pressure in the supply container, chlorine must be removed as a gas at a rate high enough to cause cooling of the remaining liquid. (See Section **Error! Reference source not found.**)

5.7 ABSORPTION SYSTEMS

Chlorine is readily absorbed in and reacted with an alkaline solution. The alkaline solution consists of water and sodium hydroxide, sodium carbonate, or potassium hydroxide. Contact your chlorine supplier and consult CI Pamphlet 89 (11.1)

5.8 EMERGENCY KITS AND RECOVERY VESSELS

Chlorine Institute Emergency Kits and cylinder recovery vessels are designed to contain most leaks which may be encountered from chlorine containers. The following kits and recovery vessels are available:

- Kit A - for 100 lb and 150 lb cylinders



- Kit B - for ton containers.



- Kit C - for tank cars and tank trucks.



- Recovery vessels for cylinders.



The kits contain step-by-step instructions for the use of the devices. The necessary tools are included, but personal protective equipment is not included. CI Pamphlets IB/A, IB/B, and IB/C (11.1) provide information on these kits and their use.

Chlorine recovery vessels are commercially available equipment designed to hold an entire cylinder. A leaking cylinder can be placed in a recovery vessel which is then closed, thus containing the leak. The chlorine can then be recaptured from the recovery vessel.

For chlorine barges, contact your supplier for information or equipment for leak mitigation.

Chlorine consumers should incorporate plans for the use of these kits in their emergency programs, provide instruction to the emergency responders, and properly maintain the equipment. Further information on the utility, availability, and purchase of kits, kit components, and audio visual training aids is available from the Institute or the chlorine supplier.

Chlorine use or storage locations should have either the appropriate emergency kit(s) or containment vessel(s) readily available with emergency responders trained in their use or have a formal arrangement with an outside emergency response group that can respond to emergencies using such equipment.

5.9 REPORTING

Most governmental agencies have reporting requirements for chlorine releases. Producers, transporters, and users of chlorine should be aware of the “reportable quantity” and of all relevant requirements.

6. **EMPLOYEE TRAINING AND SAFETY**

6.1 EMPLOYEE TRAINING

Safety in handling chlorine depends, to a great extent, upon the effectiveness of employee training, proper safety instructions and the use of suitable equipment. It is the responsibility of the employer to train employees and to document such training as appropriate and as required by regulation. It is the responsibility of employees to carry out correct operating procedures safely and to properly use the safety equipment provided.

Employee training should include but is not limited to:

- Instruction and periodic refresher courses in operation of chlorine equipment and handling of chlorine containers.
- Instruction in the properties and physiological effects of chlorine, including the information on the Safety Data Sheet (SDS).
- An SDS should be provided by the chlorine supplier.
- Instruction to report to the proper authority all equipment failures and chlorine leaks.

Instruction and periodic drills regarding:

- Locations, purpose, and use of chlorine emergency equipment, firefighting equipment, fire alarms and shutdown equipment such as valves and switches.
- Use and installation of emergency kits, such as the Chlorine Institute Emergency Kits A, B, or C and the recovery vessel if they are part of emergency equipment and planning at the location.
- Locations, purpose, and use of personal protective equipment.
- Locations, purpose, and use of safety showers, eye washes, or the closest source of water for use in emergencies.
- Locations, purpose, and use of any specialized first aid equipment.

6.2 PERSONAL PROTECTIVE EQUIPMENT

6.2.1 Availability and Use

There is a potential for exposure to chlorine whenever chlorine is handled, stored, or used. If chlorine is used in widely separated locations, personal protective equipment should be available near each use point. Personal protective equipment (PPE) for emergency use should be available away from areas of likely contamination. CI Pamphlet 65 (11.1) provides recommendations on appropriate PPE for specific tasks including loading/unloading, initial line entry, material sampling, and emergency response.

6.2.2 Respiratory Equipment

Respiratory equipment should be selected based on evaluation of hazards and degree of potential exposure. The need to protect the eyes from chlorine should be part of the evaluation of appropriate respiratory equipment. See CI Pamphlet 65 (11.1).

All personnel entering areas where chlorine is stored or handled should carry or have immediately available appropriate respiratory protection.

A self-contained breathing apparatus (SCBA), with full face piece, is required for performing tasks when chlorine may be present unless air sampling verifies the chlorine concentration is such that a lower level of respiratory protection is sufficient.

Fit testing and regular maintenance programs for respirator equipment are necessary. Documented, regularly scheduled training is required to assure competency with self-contained breathing apparatus (29 CFR 1910).

6.2.3 Minimizing Chlorine Inhalation Risk

During activities that have the potential to release chlorine, such as line breaking, leak investigation, hose connecting, taking samples, loading/unloading, returning equipment to chlorine service, or other maintenance activities, consideration should be given to ensure adequate personal protection is implemented and maintained throughout the activities. For individuals directly involved, requirements for donning personal protective equipment in relation to job progression should be specified along with conditions to downgrade, if desired, including confirmation that concentrations are below permissible exposure limits. Adjacent, downwind, or potentially impacted areas should be evaluated for risk of exposure to individuals not directly involved. Consideration should be given to limiting/restricting access to the areas and communication of higher risk activity throughout the area (area announcement, barricades, operational attendance, etc.).

6.3 CONFINED SPACE ENTRY

Confined space entry procedures must comply with all applicable local codes and regulations. The OSHA standard 29 CFR 1910.146 must be adhered to by most facilities in the United States.

CONFINED SPACE ENTRY TIPS

- Suitable respiratory and other protective equipment for anyone entering the confined space;
- Safety harness and lifeline for all workers in the confined space;
- Supervision of the operation from outside the confined space at all times;
- No entry for rescues without appropriate respiratory protection, safety harness, lifeline and backup personnel;
- See OSHA standard 29 CFR1901.164.

6.4 PERSONAL EXPOSURE MONITORING

Because the odor of chlorine in itself is an inadequate indicator of concentration, it is essential that some quantitative measure of exposure be determined. Exposure guidelines are listed on the SDS, including OSHA PEL and American Conference of Governmental Industrial Hygienists (ACGIH) TLV.

7. **MEDICAL ASPECTS AND FIRST AID**

7.1 HAZARDS TO HEALTH

Chlorine gas is primarily a respiratory irritant. At low concentrations, chlorine gas has an odor similar to household bleach. As the concentrations increase from the level of detection by smell, so do the symptoms in the exposed individual. Depending on the level of exposure to chlorine, the effects may become more severe for several days after the incident. Observations of exposed individuals should be considered part of the medical response program.

The following list is a compilation of potential chlorine exposure thresholds and potential responses in humans, with considerable variation among subjects:

Table 7.1 Chlorine Exposure Thresholds, Limits, and Guidelines (ppm)

0.2 – 0.4	Odor threshold (decrease in odor perception occurs over time)
Less than 0.5	No known acute or chronic effect
0.5	ACGIH TLV-TWA (8-hour time-weighted average)
1	OSHA PEL (ceiling) ACGIH TLV-STEL (15 minutes) AIHA ERPG-1: The maximum airborne concentration below which it is believed that nearly all individuals could be exposed for up to 1 hour without experiencing other than mild transient adverse health effects or perceiving a clearly defined, objectionable odor.

Table 7.1 Chlorine Exposure Thresholds, Limits, and Guidelines (ppm)

1 – 3	Mild mucous membrane irritation, tolerated up to 1 hour
3	AIHA ERPG-2: The maximum airborne concentration below which it is believed that nearly all individuals could be exposed for up to 1 hour without experiencing or developing irreversible or other serious health effects or symptoms which could impair an individual's ability to take protective action.
5 – 15	Moderate irritation of the respiratory tract. The gas is very irritating, and it is unlikely that any person would remain in such an exposure for more than a very brief time unless the person is trapped or unconscious
10	NIOSH IDLH: The airborne concentration that poses an immediate threat to life, would cause irreversible adverse health effects, or would impair an individual's ability to escape from a dangerous atmosphere. Values are based on a 30-minute exposure.
20	AIHA ERPG-3: The maximum airborne concentration below which it is believed that nearly all individuals could be exposed for up to 1 hour without experiencing or developing life-threatening health effects.
30	Immediate chest pain, vomiting, dyspnea (shortness of breath), and cough
40 – 60	Toxic pneumonitis (inflammation of the lungs) and pulmonary edema (accumulation of fluid in the lungs)
430	Lethal over 30 minutes
1000	Fatal within minutes.

Note: Values presented in Table 7.1 that are not designated as ACGIH, AIHA, NIOSH or OSHA values are from "Medical Toxicology: Diagnosis and Treatment of Human Poisoning," Ellenhorn, M.J. and D.G. Barceloux, Eds., Elsevier, New York (1988). pp. 878-879.

7.1.1 Acute Toxicity

The toxic effects of chlorine are due to its corrosive properties. Chlorine is primarily removed by the upper airways. Exposure to low concentrations of chlorine gas may cause irritation to the nose, respiratory tract, and eyes (burning discomfort, blinking, redness, conjunctivitis, and tearing). As concentrations increase, so does the irritating effect on the upper and lower respiratory tract, manifested as coughing with eventual difficulty breathing. Inhalation of chlorine gas at greater than 15 ppm may lead to airway constriction and accumulation of fluid in the lungs (pulmonary edema). As duration of

exposure and/or concentration increase, the affected individual may develop rapid breathing, wheezing and hemoptysis (blood in spit). In extreme cases difficulty in breathing can progress to the point of death through cardiovascular collapse from respiratory failure. An exposed person with a preexisting respiratory condition can have an exaggerated response.

7.1.2 Chronic Toxicity

Most studies indicate no significant connection between adverse health effects and chronic exposure to low concentrations of chlorine. However, a 1983 Finnish study (Grenquist-Norden, B.: Institute of Occupational Health, pp. 1-83, 1983) did show an increase in chronic coughs and a tendency for hypersecretion of mucous among workers. These workers showed no abnormal pulmonary function in tests or chest x-rays.

7.1.3 Eye and Skin Contact

Contact of liquid chlorine with eyes will result in serious thermal and/or chemical burns. Prolonged contact of gaseous chlorine with eyes can cause irritation at low concentrations and serious eye injury at higher concentrations. Care should be taken when using respiratory protection to avoid or limit eye exposure. Contact with skin will cause local chemical or thermal (frostbite) burns.

7.2 FIRST AID

First aid is the immediate temporary treatment given to an exposed individual before the services or recommendations of a physician are obtained. Prompt action is essential. Reassurance to the individual will help to alleviate anxiety. Medical assistance must be obtained as soon as possible. Never give anything by mouth to an unconscious or convulsing person. If chlorine has saturated an exposed person's clothes or skin, decontamination should be done by removing affected clothing and showering as recommended on the SDS.

Responders should take the necessary precautions to protect themselves from any exposure to chlorine while administering first aid and should move the victim from the contaminated area as soon as possible.

CI Pamphlet 63 (11.1) contains detailed guidance on first aid for chlorine exposure, including:

- Inhalation
- Respiratory Assistance
- Oxygen Administration
- Skin Contact
- Eye Contact
- Medical Management of Chlorine Exposures

- Delayed Effects

A brief summary of key first aid points follows below.

7.2.1 Inhalation

An individual with chlorine inhalation exposure should be evaluated by the first responder for adequate airway, breathing, and circulation. If the airway is obstructed remove the obstruction. If breathing has apparently ceased, the victim should be given cardiopulmonary resuscitation (CPR) immediately. If breathing has not ceased, the exposed individual should be placed in a comfortable position. In severe cases the person should lie down with the head and trunk elevated to a 45-60° position (unless there is a medical contraindication). Slow, deep breathing should be encouraged.

Historically, oxygen therapy has been considered the primary treatment for chlorine inhalations. While it may not be necessary for all cases of chlorine inhalation, oxygen therapy is recommended in any case in which an individual continues to be symptomatic after leaving the area of exposure. Oxygen should be administered by first aid providers trained in the use of the specific oxygen equipment. Humidified oxygen is preferred since the humidity soothes the irritation to the mucous membranes, while oxygen without humidity can have a drying effect, potentially aggravating the irritant symptoms. However, oxygen without humidity should not be withheld if oxygen therapy is indicated.

Suitable equipment for the administration of oxygen and personnel trained in the use of the equipment should be available either on-site or at a nearby facility. Such equipment should be periodically tested.

The inhalation of any irritating gas may lead to delayed reactions, such as pulmonary edema. Since physical exercise appears to have some relation with the incidence of delayed reaction, it is recommended that any patient who has had a severe inhalation exposure should be kept at rest for a period of observation. Irritants (cigarette smoke, dust, etc.) should be avoided during this period of observation. The length of the period of observation will depend on the clinical assessment of the exposed individual.

7.2.2 Contact with Skin

If liquid chlorine has contaminated the skin or clothing, an emergency shower should be used immediately and the contaminated clothing should be removed under the shower. Flush contaminated skin with copious amounts of tepid water for 15 minutes or longer. Do not attempt chemical neutralization or apply any salves or ointment to damaged skin. Refer to a qualified health care provider if irritation persists after irrigation or if skin is broken or blistered.

7.2.3 Contact with Eyes

If eyes have been exposed to liquid chlorine or become severely irritated due to exposure to high concentration of chlorine gas they should be flushed immediately with copious amounts of tepid water for at least 15 minutes. Do not attempt to neutralize with chemicals. The eyelids should be held apart to ensure water contacts all accessible tissue of the eyes and lids. Medical assistance must be obtained as soon as possible. If

such assistance is not immediately available continue eye irrigation for a second 15-minute period.

7.3 MEDICAL SURVEILLANCE

The Chlorine Institute recommends a medical surveillance program, which would include baseline and periodic examinations, for personnel working in chlorine production, use, or handling facilities who are potentially exposed to chlorine, at or above the ACGIH® guideline of 0.5 ppm TWA or 1 ppm STEL during normal operations. Additional information on a medical surveillance program can be found in CI Pamphlet 63 (11.1).

8. **ENGINEERING DESIGN AND MAINTENANCE**

8.1 STRUCTURES

Buildings and structures to house chlorine equipment or containers should conform to local building and fire codes. Any building used to house chlorine equipment or containers should be designed and constructed to protect all elements of the chlorine system from hazards. If flammable materials are stored or used in the same building, then a fire wall should be erected to separate the two areas. Non-combustible construction is recommended.

Chlorine monitoring equipment which continuously samples the air and detects the presence of chlorine is available and should be considered in any storage or operating area where chlorine can be released. See CI Pamphlet 73 (11.1).

At least two exits should be provided from each separate room or building in which chlorine is stored, handled or used. Exit doors should not be locked and should open outward. Platforms should be designed to facilitate egress and two or more access stairways or ladders should be considered. Steel structures should be protected to prevent corrosion.

8.2 VENTILATION

The ventilation requirements must be determined on a site-specific basis.

8.2.1 General

The building ventilation system should provide fresh air for normal operation and should take into consideration the possibility of a chlorine leak. In some cases, natural ventilation may be adequate; otherwise, mechanical ventilation systems should be installed. Safeguards should be in place to ensure that persons do not remain in nor enter buildings where chlorine is present in the atmosphere due to a leak or equipment failure without the appropriate personal protective equipment. All ventilation systems for buildings that house equipment or containers should conform to applicable building code requirements and American Conference of Governmental Industrial Hygienists (ACGIH) recommendations.

8.2.2 Air Openings

Chlorine gas is heavier than air and has a tendency to collect at floor level. The exhaust air system should draw from a location at or near floor level. An elevated fresh air inlet must be provided and should be located for adequate cross ventilation. Multiple fresh air inlets and fans may be necessary to facilitate adequate ventilation. Fans, if used, should be made to start and stop from a safe, remote location.

Alternatively, it may be desirable to pressurize an installation with fresh air and to exhaust the contaminated air through outlets at floor level.

8.2.3 Heating

Rooms containing chlorinator feed equipment should be maintained at a normal indoor temperature to facilitate gas discharge rates from the container. Extreme room temperatures should be avoided in order to prevent an accidental chlorine release due to melting of the fuse plug.

8.3 MATERIAL FOR PROCESSING EQUIPMENT

Materials of construction for handling dry chlorine and wet chlorine are very different. Temperature also plays an important role in material selection. (See CI Pamphlets 6, 100, and 164 (11.1)).

8.3.1 General

Commercial liquid chlorine contains only minor amounts of impurities and is dry enough to be handled in carbon steel equipment. In the manufacturing process, certain properties unique to chlorine should be considered when considering the materials of construction.

8.3.2 Water in Chlorine

Wet chlorine may be safely handled with a variety of materials which can be chosen to suit the process conditions. Some materials, such as titanium, are suitable for wet chlorine but not for dry chlorine. Titanium reacts violently with dry chlorine. Titanium is a safe material in wet gaseous chlorine service provided the percentage of water in the chlorine vapor is sufficient to passivate the titanium metal. This is dependent on the total pressure and temperature of the system. Use CI Pamphlet 165 (11.1) to determine the safe conditions for titanium in wet chlorine service.

8.3.3 Temperature

Carbon steel used in the handling of dry chlorine must be kept within definite temperature limits. Where process temperatures are expected to exceed 300°F (149°C), the material used should be more resistant than carbon steel to high temperature corrosion by chlorine. Above 300°F (149°C) chlorine can rapidly attack and ignite the steel. Impurities in the chlorine and/or a high surface area of the steel may significantly lower the auto-ignition temperature of chlorine and steel.

There is also a possibility of brittle fracturing in certain chlorine processing equipment and storage tanks. Where this is the case, a type of steel should be used that can withstand the lowest temperatures possible in the process.

8.3.4 Alternative Materials

Several chemicals are normally involved in the manufacture of chlorine, including hydrogen, sulfuric acid, mercury, certain salts, oxygen and various products of their reaction with chlorine. Materials of construction should be selected to guard against these corrosive or hazardous materials that are present in the manufacturing process.

8.4 VAPORIZERS

High capacity chlorine gas feed systems may need a chlorine vaporizer (evaporator). Vaporizers are designed to convert liquid chlorine into chlorine gas. Steam or hot water jackets are used to provide the heat needed for vaporization. Temperature control is critical. Pressure relief through the use of a safety valve with a rupture disk is required for vaporizers. Careful attention must be given to the design and operation of such systems. Maintaining a heat source below 250°F (121°C) to avoid possible steel/chlorine reactions, controlling NCl_3 levels and monitoring condensate for chlorine leakage are examples of some prudent operating discipline steps that should be taken. Periodic cleaning is necessary and the manufacturer's recommendations should be followed. See CI Pamphlet 9 (11.1) for more detailed information on vaporizer operation & design.

8.5 SUPPORT EQUIPMENT

8.5.1 General

Equipment used in chlorine must be designed either for dry chlorine or wet chlorine applications so that proper materials of construction are selected. Most equipment used in chlorine service is built to a specific design code or regulation. Such codes or regulations include ANSI, API, ASME and TEMA standards and OSHA regulations. See CI Pamphlet 5 (11.1).

8.5.2 Vessels

Materials of construction for vessels used in wet chlorine applications include certain plastic-lined or rubber-lined steel, reinforced polyesters, and titanium. Vessels used in dry chlorine service are usually carbon steel.

The minimum fabrication standard for metal vessels operating at greater than 15 psig is that given in the ASME Code (Reference 11.5.1) for pressure vessels. Vessels operating at less than 15 psig have no ASME code requirements, but should be designed according to manufacturer's specification. Vessels in vacuum service require special designs to prevent collapse.

8.5.3 Heat Exchangers

Heat exchangers should be designed and fabricated in accordance with the TEMA Standard and proper ASME material classifications and codes. Titanium is usually the choice for wet chlorine, and carbon steel is normally used for dry chlorine.

It is important to ensure the heat exchanger is cleaned and ready for chlorine service. The reaction of residual organics/lubricants in the equipment with chlorine presents a potential fire hazard. See CI Pamphlet 6 (11.1) for details on "Preparation for Use".

8.5.4 Pumps

Pumps for chlor-alkali service are constructed of a wide range of materials. A supplier of such pumps should be contacted for design and use, such as certain plastic-lined or rubber-lined steel, reinforced polyester and titanium.

Liquid chlorine pumps are special items with particular risks to be considered and managed. As with all rotating equipment in chlorine service an abrasion can result in a chlorine/metal fire and subsequent chlorine release. Appropriate interlocks/shutdowns should be put in place to minimize these risks.

8.5.5 Compressors and Blowers

Compressors used in dry chlorine service include centrifugal, non-lubricated reciprocating, and liquid-ring sealed (sulfuric acid). Compressors and blowers should be built in accordance with the applicable ASME code and supplier specifications. Aluminum, copper and copper alloys must be avoided.

As with all rotating equipment in chlorine service an abrasion can result in a chlorine/metal fire and subsequent chlorine release. Discharge temperatures should be designed and managed to assure that the limits of the equipment metallurgy are not exceeded.

Fans are sometimes used to boost pressure or move chlorine gas in vent or scrubber systems. In wet chlorine service, rubber-lined, fiberglass reinforced polyester or titanium are normally used. In dry chlorine service, carbon steel is normally used.

8.5.6 Scrubbers

While scrubbers are an effective means of absorbing chlorine, the need for a scrubber should be based on a site-specific hazard assessment that considers factors such as the quantity of chlorine on site, the likelihood of a release, and the consequences of a release. The design of the scrubber depends on the quantity of chlorine to be absorbed, the flow rate of air through the scrubber and the scrubbing liquid. See CI Pamphlet 89 (11.1).

8.6 PIPING SYSTEMS FOR DRY CHLORINE

Piping as described in this section pertains only to above ground fixed piping. See CI Pamphlet 6 (11.1).

8.6.1 Materials

In general, ASTM A106 Grade B Schedule 80 seamless carbon steel piping is recommended for handling dry chlorine when the process temperature range is from -20°F to 300°F (-29°C to 149°C). Stainless steels of the 300 series have useful properties for low temperature service but can fail due to chloride stress corrosion

cracking, particularly in the presence of moisture at ambient or elevated temperatures. Certain metal piping materials, including titanium, aluminum, gold, and tin, cannot be used with dry chlorine.

Some plastics can be used under certain conditions. See CI Pamphlet 6 (11.1). Plastic piping can become brittle in chlorine service and has a limited service life. Periodic inspection and replacement is recommended.

8.6.2 Design and Installation

General Design

Piping arrangements should be routed for the shortest distance practical with respect to flexibility, line expansion, and good engineering practice. Piping systems should be properly supported, adequately sloped to allow drainage, and low spots should be minimized. Avoid installing lines next to steam lines, acid lines, or any other lines that could cause corrosion of the chlorine line. Chlorine piping should be protected from all risks of excessive heat or fire.

Periodic inspection and replacement is recommended for all piping systems in chlorine service.

For detailed information on piping material selection and general design, see CI Pamphlet 6 (11.1). Items that should be considered for piping design in CI Pamphlet 6 include:

- Liquid Expansion - Liquid chlorine has a high coefficient of thermal expansion. If liquid chlorine is trapped between two closed valves, an increase in temperature of the trapped liquid will result in high pressures potentially leading to a rupture of the line. The causes of possible rupture must be considered in the design of any piping systems. Protection may be either a suitably designed, operated and maintained expansion chamber, a pressure relief valve, or a rupture disc.
- Condensation - Condensation or reliquefaction of chlorine may occur in chlorine gas lines which pass through areas where the temperature is below the temperature-pressure equilibrium. Condensation can usually be prevented by the use of a pressure reducing valve or heat tracing and insulating the line. Any heat tracing installation should be designed such that the surface temperature of the pipe shall not exceed 300°F (149°C) to limit the possibility of a chlorine/carbon steel reaction.
- Installation – Joints in chlorine piping may be flanged, screwed or welded depending on piping size, though flanged and screwed joints should be kept to a minimum. If screwed joints are used, extreme care should be taken to obtain clean and sharp threads. Before cutting or welding on a chlorine line, a determination must be made that the system is chlorine free. Dry chlorine can support combustion of carbon steel, nickel and other materials.
- Routing

- Valves
- Inspection and Maintenance
- Other Components

Preparation for Use

Cleaning

All portions of new piping systems must be cleaned before use because chlorine can react violently with cutting oil, grease, and other foreign materials. Cleaning must not be done with hydrocarbons or alcohols, since chlorine may react violently with many solvents. New valves or other equipment received in an oily condition should be dismantled and cleaned before use. See CI Pamphlet 6 (11.1).

Pressure Testing

New chlorine piping systems should be tested according to one of the methods recommended in CI Pamphlet 6 (11.1). Components which may be damaged during testing should be removed or blocked off. After testing, all moisture-absorbing gaskets and valve packings should be replaced; it is essential that chlorine systems be dried as described below prior to being placed into service.

Drying

Chlorine piping systems must always be dried prior to use. Even if water has not been purposely introduced into the system from hydrostatic testing or cleaning, drying is still required due to the introduction of moisture from the atmosphere or other sources during maintenance and new construction.

Drying can be facilitated as the system is cleaned by passing steam through the lines from the high end until the lines are heated. While steaming, the condensate and foreign matter is drained out. The steam supply then should be disconnected and all the pockets and low spots in the line drained. While the line is still warm, dry air or inert gas (e.g., nitrogen) having a dew point of -40°F (-40°C) or below should be blown through the line until the discharge gas is also at a dew point of -40°F (-40°C) or below.

If steam or dry utility system air are not available, particular care must be taken in cleaning sections of pipe and other equipment before assembly, and careful inspection is necessary as construction proceeds. The final assembled system should be purged with dry cylinder air or nitrogen until the discharge gas is at a dew point of -40°F (-40°C) or below.

Leak Testing

After drying, the system should be leak-tested with dry air or nitrogen. A soap solution should be utilized to test for leaks at piping joints. Chlorine gas may then be introduced gradually and the system further tested for leaks with 26° Baumé (30 wt.%) aqua ammonia vapor. Care must be taken that chlorine has diffused throughout the piping systems before testing for leaks. Never attempt to repair leaks by welding until all

chlorine has been purged from the system. When leaks have been repaired, the line should be retested.

8.7 PIPING SYSTEMS FOR WET CHLORINE

Wet chlorine is very corrosive to all of the more common construction metals. Materials must be selected with care.

At low pressures, wet chlorine can be handled in chemical stoneware, glass, or porcelain equipment and in certain alloys.

Hard rubber, unplasticized polyvinyl chloride, fiberglass reinforced polyester, polyvinylidene chloride or fluoride and fully halogenated fluorocarbon resins have been used successfully.

For higher pressures, lined metallic or compatible metallic systems should be used.

Hastelloy® C, titanium, and tantalum have been used.

Titanium may only be used with sufficiently wet chlorine but must not be used with dry chlorine under any circumstances, as it burns spontaneously on contact.

Tantalum is inert to wet and dry chlorine at temperatures up to 300°F (149°C).

8.8 STATIONARY STORAGE

Consumers receiving chlorine in barges, tank cars or trucks may require stationary storage facilities. The facilities should be properly designed and should be operated and periodically inspected in accordance with CI Pamphlet 5 (11.1).

A tank should not be filled beyond its rated chlorine capacity because liquid chlorine will expand as it warms. At normal storage temperatures, the thermal expansion rate of liquid chlorine is high and, if room for expansion is not provided, could increase the hydrostatic pressure enough to rupture the tank. The maximum chlorine level should be determined by the filling density as discussed in Section 2.5.11.

8.9 EQUIPMENT MAINTENANCE

8.9.1 General

All chlorine piping and equipment should be carefully inspected on a regular basis. Inspections can be done using ultrasonic thickness testing, eddy current testing, magnetic flux testing, and other non destructive testing. See CI Pamphlet 6 (11.1).

Maintenance of chlorine equipment and tanks should be under the direction of trained personnel. All precautions pertaining to safety education, protective equipment, health, and fire hazards should be reviewed and understood. Workers should not attempt to repair chlorine piping or other equipment while it is in service. When a chlorine system is to be cleaned or repaired, tanks, piping and other equipment should always be purged with dry air or non-reactive gas. All significant piping or process changes must follow a

Management of Change (MOC) process. See the OSHA Process Safety Management (PSM) regulations for MOC guidelines.

Decontamination is especially important where cutting or welding operations are undertaken because iron and steel can ignite in chlorine near 300°F (149°C). Immediate drying of chlorine equipment, piping, or containers into which water has been introduced or which has been opened for repairs or cleaning is essential to prevent corrosion.

Cleaning of piping and other equipment is addressed in CI Pamphlet 6 (11.1).

8.9.2 Entering Tanks

Chlorine tank inspection, cleaning and repair are discussed in CI Pamphlet 5 (11.1). OSHA has specific regulations concerning the entering of confined spaces. These regulations should be thoroughly understood and followed. See OSHA standard 29 CFR 1910.146.

8.10 CHLORINE NEUTRALIZATION

If a chlorine consuming process involves the discharge of a waste containing chlorine, special processes may be required. All governmental regulations regarding health and safety or the protection of natural resources must be followed. A system should be provided to neutralize any chlorine vented for maintenance preparation or process upset, such as a sudden failure of the chlorine compressor, trouble during the start-up of a circuit, or a breakdown of the tail gas handling system.

The neutralization is usually accomplished by causing the chlorine to react with sodium hydroxide solution or, in certain situations, with another alkaline compound. Neutralization can take place in an appropriately designed tank or in a scrubber. The sodium hydroxide concentration should be less than 20% to prevent precipitation of sodium chloride crystals (salting-out) and excessive heat of reaction. See CI Pamphlet 89 (11.1).

9. **U.S. REGULATIONS AND CODES**

Note: The purpose of this section is to provide a list of some of the regulations that significantly affect the production, storage, packaging, distribution, or use of chlorine in the United States.

Additionally, information is provided on some of the Fire Codes that similarly affect chlorine. This section is not meant to cover all regulations affecting chlorine.

9.1 OCCUPATIONAL SAFETY AND HEALTH REGULATIONS -29 CFR PARTS 1904 AND 1910

9.2 NAVIGATION AND NAVIGABLE WATER REGULATIONS -33 CFR PARTS 1-26, 126, 127, 130, 153-156 AND 160-167

9.3 ENVIRONMENTAL REGULATIONS - 40 CFR: PROTECTION OF ENVIRONMENT; PARTS 61, 68, 82, 141, 152, 260-269, 302-355, 370-372, 415 AND 700-799

9.4 SHIPPING REGULATIONS - 46 CFR (WATER TRANSPORTATION); PARTS 2, 10-12, 30-40 AND 151

9.5 TRANSPORTATION REGULATIONS - 49 CFR PARTS 106, 107, 171-180 AND 190-195

9.6 DEPARTMENT OF HOMELAND SECURITY – 6 CFR PART 27

9.7 FIRE CODES

Numerous fire and building codes exist that affect chlorine production, storage, packaging, distribution, and use. To properly address these codes, the local government should be contacted to determine what specific fire and building codes, including the code year, were passed by the governing jurisdiction.

Some local or state authorities develop their own codes. However, many jurisdictions adopt a model code or reference National Fire Protection Association (NFPA) Standards. Either of these may serve as the local code(s). The model codes are modified annually and yearly supplements are issued. New editions of the codes are published every third year. The code year is important in determining which code is applicable. The specific requirements are contained in the applicable code.

10. TECHNICAL DATA

10.1 GENERAL

Chlorine has a characteristic penetrating and irritating odor. The gas is greenish yellow in color and the liquid is clear amber. The data on physical properties of chlorine as determined by different investigators show some variations.

10.2 ATOMIC AND MOLECULAR PROPERTIES

Atomic Symbol - Cl

Atomic Weight - 35.453

Atomic Number - 17

Molecular Weight of Cl₂ - 70.906

10.3 CHEMICAL PROPERTIES

Table 10.1 Physical Properties

Property	Definition	Conditions	Value
Boiling Point (Liquefying Point)	The temperature at which liquid chlorine vaporizes	14.696 psia (101.325 kPa)	-29.15°F (-33.97°C)

Table 10.1 Physical Properties

Property	Definition	Conditions	Value
Critical Density	The mass of a unit volume of chlorine at the critical pressure and temperature		35.77 lb/ft ³ (573.0 kg/m ³)
Critical Pressure	The vapor pressure of liquid chloride at the critical temperature		1157.0 psia (7977 kPa)
Critical Temperature	The temperature above which chlorine exists only as a gas no matter how great the pressure		290.75°F (143.75°C)
Critical Volume	The volume of a unit mass of chlorine at the critical pressure and temperature		0.02795 ft ³ /lb (0.001745 m ³ /kg)
Density	The mass of a unit volume of chlorine at specified conditions of temperature and pressure.		See Figure 10.2.
Density of Cl ₂ Gas		32°F, 14.696 psia (0°C, 101.325 kPa)	0.2006 lb/ft ³ (3.213 kg/m ³)
Density of Saturated Cl ₂ Gas		32°F, 53.51 psia (0°C, 368.9 kPa)	0.7632 lb/ft ³ (12.23 kg/m ³)
Density of Saturated Cl ₂ Liquid		32°F, 14.696 psia (0°C, 101.325 kPa)	91.56 lb/ft ³ (1467 kg/m ³)
		60°F, 86.58 psia (15.6°C, 597.0 kPa)	88.76 lb/ft ³ 11.87 lb/gal (1422 kg/m ³)
Latent Heat of Vaporization	The heat required to evaporate a unit weight of chlorine	At the normal boiling point	123.9 Btu/lb (288.1 kJ/kg)
Liquid-Gas Volume Relationship	The weight of one volume of liquid chlorine equals the weight of 456.5 volumes of chlorine gas.	32°F, 14.696 psia (0°C, 101.325 kPa)	
Melting Point (Freezing Point)	The temperature at which solid chlorine melts or liquid chlorine solidifies	14.696 psia (101.325 kPa)	-149.76°F (-100.98°C)

Table 10.1 Physical Properties

Property	Definition	Conditions	Value
Solubility in Water	The weight of chlorine which can be dissolved in a given amount of water at a given temperature when the total vapor pressure of chlorine and the water equals a designated value.	60°F, 14.696 psia (15.6°C, 101.325 kPa)	6.93 lbs/100gal (8.30 kg/m ³) See Figure 10.3
Specific Gravity of Cl ₂ Gas	The ratio of the density of chlorine gas at standard conditions to the density of air under the same conditions:	32°F, 14.696 psia (0°C, 101.325 kPa)	2.485 (Note: The density of air, free of moisture at the same conditions is 1.2929 kg/m ³)
Specific Gravity of Cl ₂ Liquid	The ratio of the density of saturated liquid chlorine to the density of water at its maximum density, 39°F (4°C)	32°F (0°C)	1.467
Specific Heat	The heat required to raise the temperature of a unit weight of chlorine one degree.		
Saturated Gas at constant pressure		32°F (0°C) 77°F (25°C)	0.1244 Btu/lb·°F (0.521 kJ/kg·K) 0.1347 Btu/lb·°F (0.564 kJ/kg·K)
Saturated Gas at constant volume		32°F (0°C) 77°F (25°C)	0.08887 Btu/lb·°F (0.372 kJ/kg·K) 0.09303 Btu/lb·°F (0.3895 kJ/kg·K)
Saturated Liquid		32°F (0°C) 77°F (25°C)	0.2264 Btu/lb·°F (0.948 kJ/kg·K) 0.2329 Btu/lb·°F (0.975 kJ/kg·K)
Ratio for Saturated Gas	Ratio of gas specific heat at constant pressure to gas specific heat at constant volume	32°F (0°C) 77°F (25°C)	1.400 1.448
Specific Volume	The volume of a unit mass of chlorine at specified conditions of temperature and pressure.		

Table 10.1 Physical Properties

Property	Definition	Conditions	Value
Gas		32°F, 14.696 psia (0°C, 101.325 kPa)	4.986 ft ³ /lb (0.3113 m ³ /kg).
Saturated Gas		32°F (0°C)	1.310 ft ³ /lb (0.08179 m ³ /kg).
Saturated Liquid		32°F (0°C)	0.01092 ft ³ /lb (0.0006818 m ³ /kg)
Vapor Pressure	The absolute pressure of chlorine gas above liquid chlorine when they are in equilibrium	32°F (0°C) 77°F (25°C)	53.51 psia (368.9 kPa) 112.95 psia (778.8 kPa)
Viscosity	The measure of internal molecular friction when chlorine molecules are in motion		
Saturated Gas		32°F (0°C) 60°F (15.6°C)	0.0125 cP (0.0125 mPa·s) 0.0132 cP (0.0132 mPa·s)
Liquid		32°F (0°C) 60°F (15.6°C)	0.3863 cP (0.3863 mPa·s) 0.3538 cP (0.3538 mPa·s)
Volume – Temperature Relationship	Volume – Temperature relationship of liquid chlorine in a container loaded to its authorized limit		Figure 10.4
Solubility of Water in liquid chlorine			Figure 10.5 and Figure 10.6

10.3.1 Flammability

Chlorine is neither explosive nor flammable. Chlorine will support combustion under certain conditions. Many materials that burn in oxygen (air) atmospheres will also burn in chlorine atmospheres. Many organic chemicals react readily with chlorine, sometimes violently. An important specific compound of concern is hydrogen. Chlorine reacts explosively with hydrogen in a range of 4% to 93% hydrogen. The reaction is initiated very easily much the same way as hydrogen and oxygen. See Pamphlet 121 for more information.

10.3.2 Valence

Chlorine usually forms compounds with a valence of -1 but it can combine with a valence of +1, +2, +3, +4, +5, or +7.

10.3.3 Chemical Reactions

Reactions with Water

Chlorine is only slightly soluble in water (0.3% to 0.7%) depending on the water temperature. However the resulting water phase is extremely corrosive, see Reactions with Metals below.

Reactions with Metals

The reaction rate of dry chlorine with most metals increases rapidly above a temperature which is characteristic for the metal. Two of the more common metals are titanium and steel. In the presence of dry chlorine, titanium is flammable. Care should be taken to make sure titanium materials are not used in dry chlorine service. Steel is the most common material used in dry chlorine service. At temperatures above 300°F (149°C) a chlorine/steel fire can result. It is important to make sure steel in chlorine service does not go above this temperature either through internal/external heating or mechanical abrasion. Moist chlorine, primarily because of the hydrochloric and hypochlorous acids formed through hydrolysis, is very corrosive to most common metals. Platinum, silver, tantalum and titanium are resistant. Consult CI Pamphlet 6 (11.1) for detailed information on reactivity with metals.

Reactions with Organic Compounds

Chlorine reacts with many organic compounds to form chlorinated derivatives. Some reactions can be extremely violent, especially those with hydrocarbons, alcohols and ethers. Proper methods must be followed, whether in laboratory or plant, when organic materials are reacted with chlorine.

10.4 PHYSICAL PROPERTIES

Figure 10.1 through Figure 10.6 are for pure chlorine.

Figure 10.1 Vapor Pressure of Liquid Chlorine
(Calculated from data in CI Pamphlet 72)

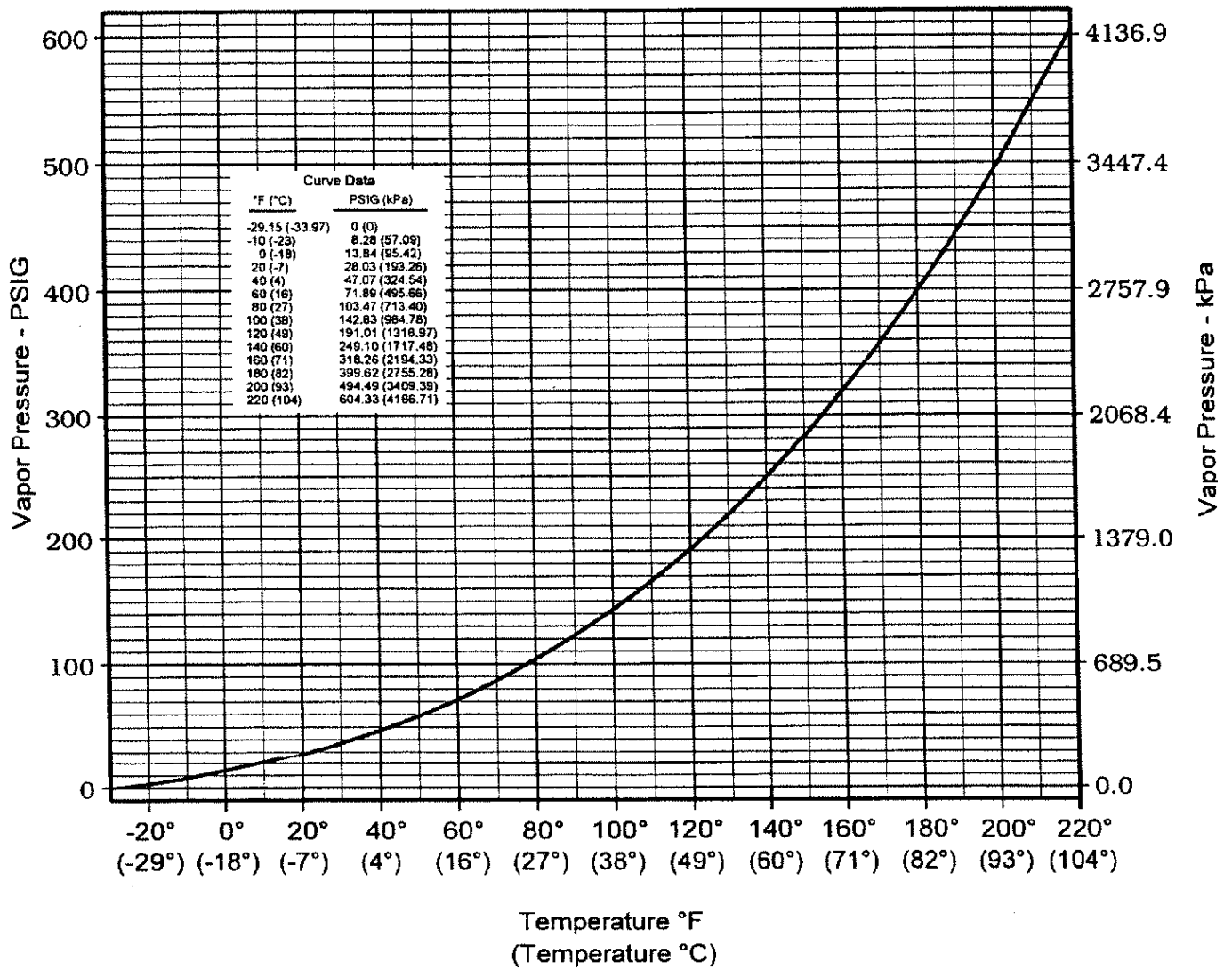

Figure 10.2 Temperature-Density Relation of Liquid Chlorine
(Calculated from data in CI Pamphlet 72)

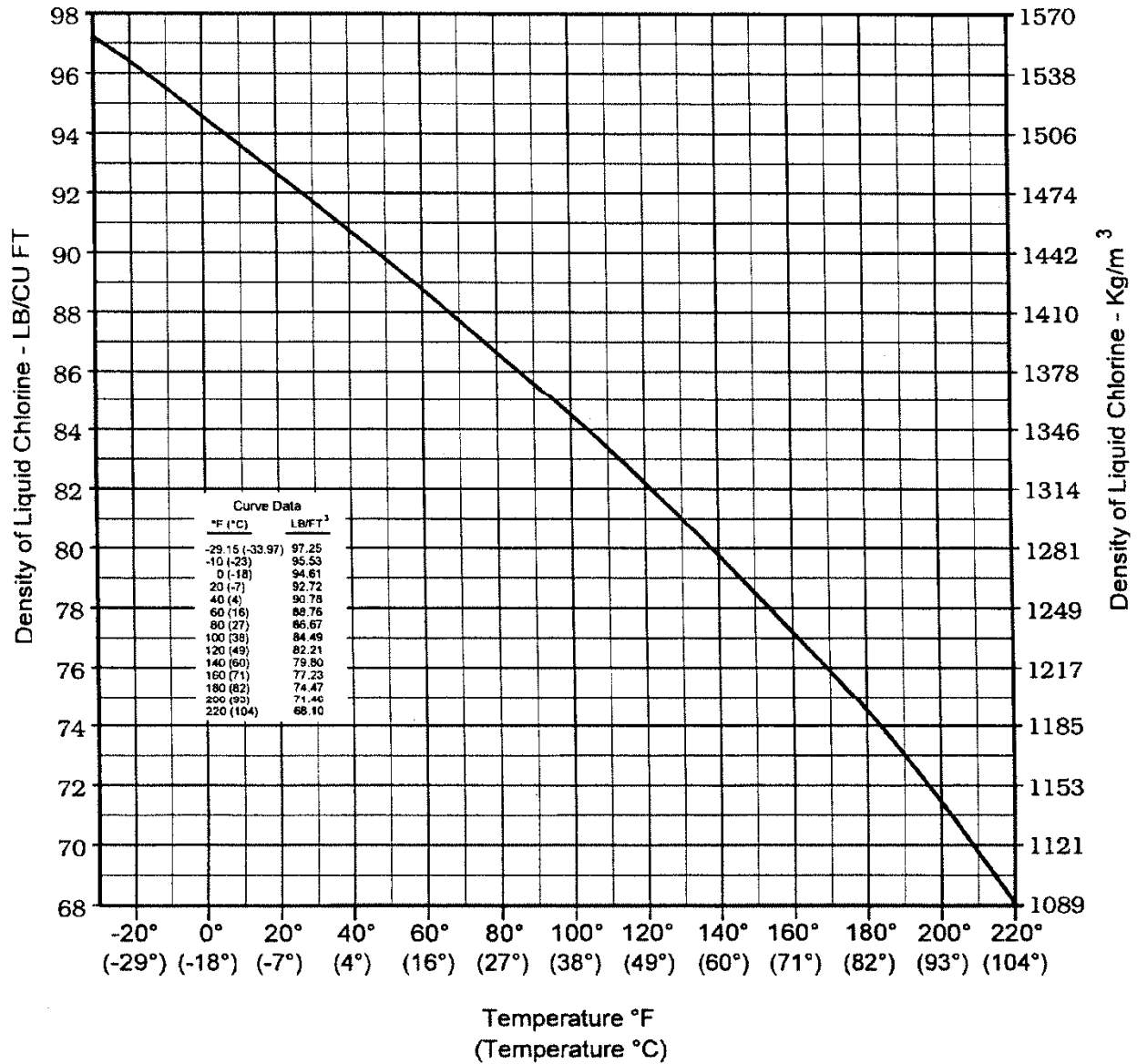

Figure 10.3 Equilibrium Solution of Chlorine In Water
(Reference 11.18.1)

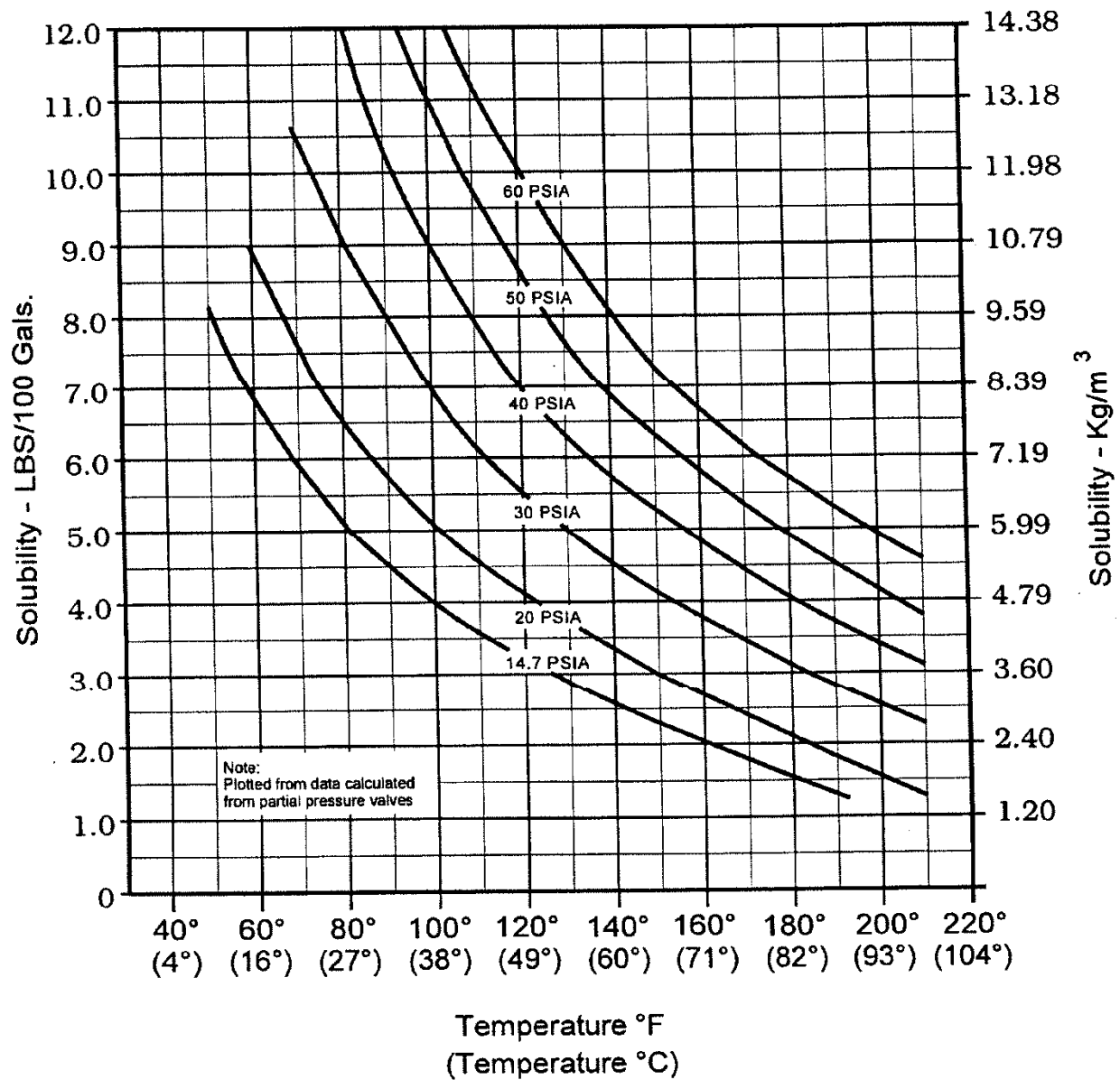

Figure 10.4 Volume-Temperature Relation of Liquid Chlorine in a Container Loaded to its Authorized Limit
(Calculated from data in CI Pamphlet 72)

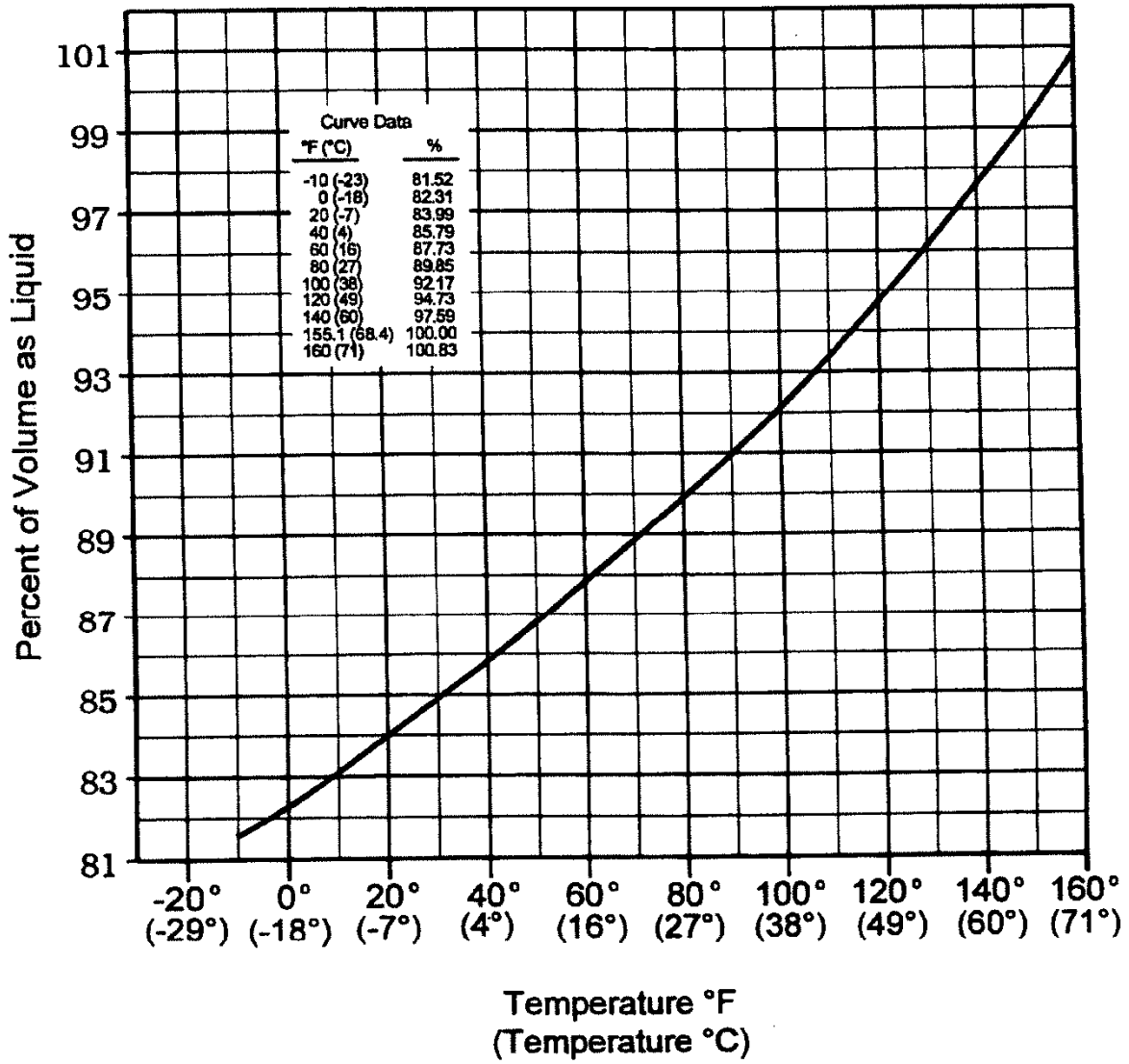
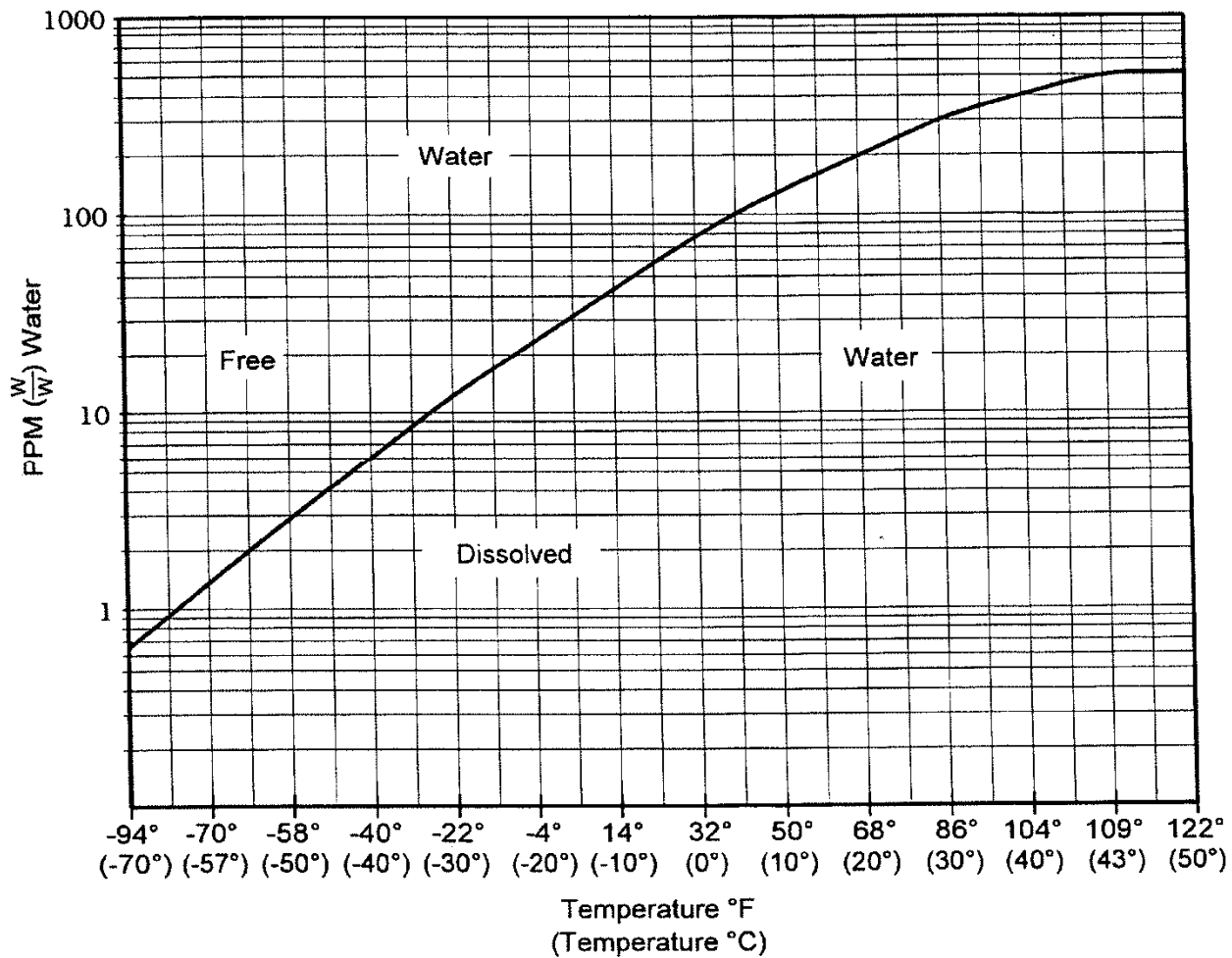

Figure 10.5 Solubility of Water in Liquid Chlorine
(Reference CI Pamphlet 100)



Note: Above the curve, the chlorine is wet. Below the curve, the chlorine is dry.

The following are examples using this figure:

- Chlorine with a water content of 30 ppm at a temperature of 50°F (10°C) is dry. If this same chlorine were at a temperature of -4°F (-20°C) the chlorine is wet.
- Chlorine at 41°F (5°C) is dry if the water content does not exceed 100 ppm.

Figure 10.6 Solubility of Water in Liquid Chlorine
(Reference CI Pamphlet 100)

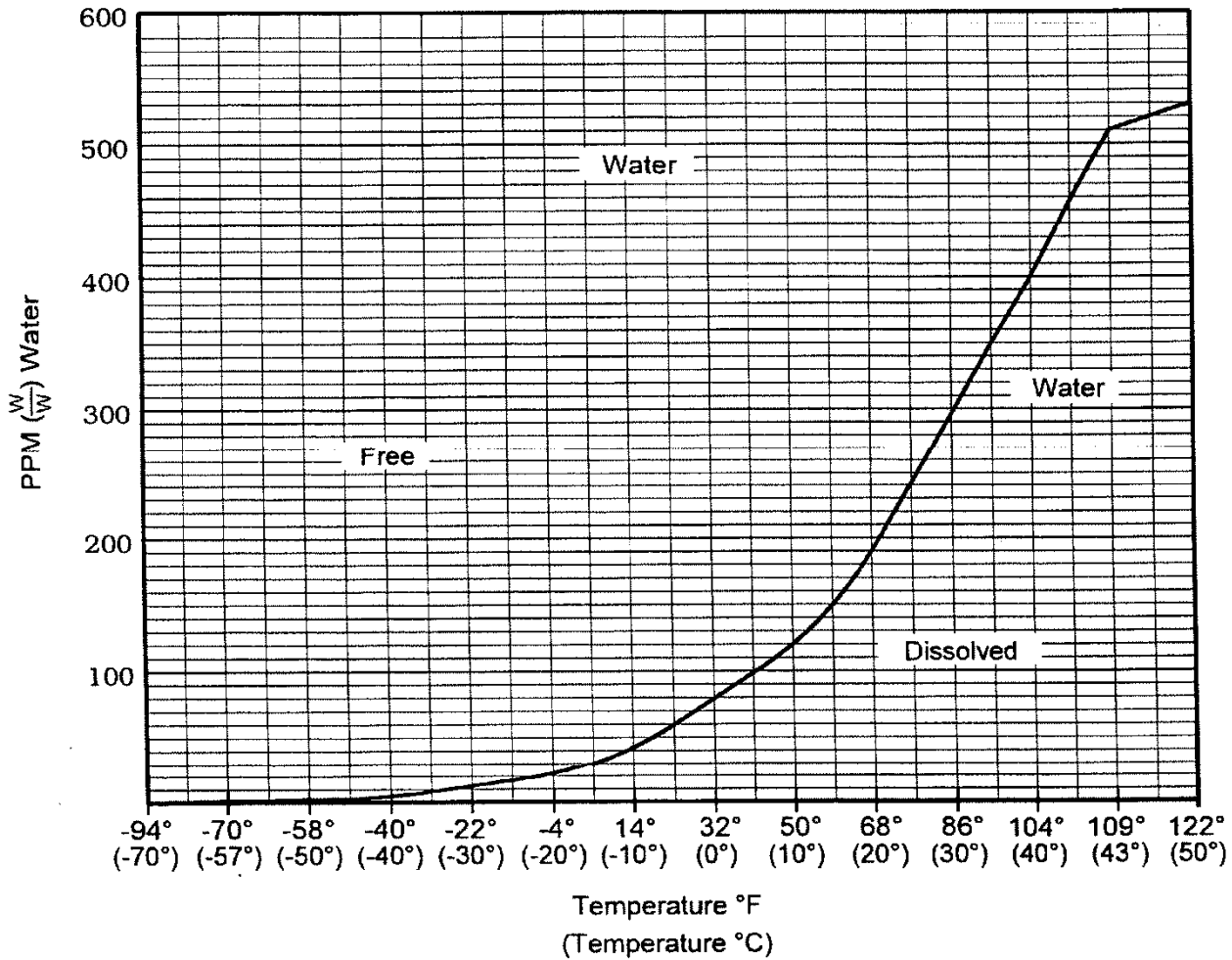

Note: Above the curve, the chlorine is wet. Below the curve, the chlorine is dry. The following are examples using this figure:

- Chlorine with a water content of 30 ppm at a temperature of 50°F (10°C) is dry. If this same chlorine were at a temperature of -4°F (-20°C) the chlorine is wet.
- Chlorine at 41°F (5°C) is dry if the water content does not exceed 100 ppm.

11. REFERENCES

The following sections provide detailed bibliographic information on Chlorine Institute publications and other documents.

11.1 CHLORINE INSTITUTE REFERENCES

The following publications are specifically referenced in CI Pamphlet 1. The latest editions of CI publications may be obtained at www.chlorineinstitute.org.

<u>Pamphlet #</u>	<u>Title</u>
5	<i>Bulk Storage of Liquid Chlorine</i> , ed. 8; Pamphlet 5; The Chlorine Institute: Arlington, VA, 2011 .
6	<i>Piping Systems for Dry Chlorine</i> , ed. 16; Pamphlet 6; The Chlorine Institute: Arlington, VA, 2013 .
9	<i>Chlorine Vaporizing Systems</i> , ed. 7; Pamphlet 9; The Chlorine Institute: Arlington, VA, 2011 .
17	<i>Packaging Plant Safety and Operational Guidelines</i> , ed. 4, Rev. 2; Pamphlet 17; The Chlorine Institute: Arlington, VA, 2011 .
21	<i>Nitrogen Trichloride – A Collection of Reports and Papers</i> , ed. 6, Pamphlet 21; The Chlorine Institute: Arlington, VA, 2010
49	<i>Recommended Practices for Handling Chlorine Bulk Highway Transports</i> , ed. 9; Pamphlet 49; The Chlorine Institute: Arlington, VA, 2009 .
63	<i>First Aid, Medical Management/Surveillance and Occupational Hygiene Monitoring Practices for Chlorine</i> , ed. 8; Pamphlet 63; The Chlorine Institute: Arlington, VA, 2011 .
64	<i>Emergency Response Plans for Chlor-Alkali, Sodium Hypochlorite, and Hydrogen Chloride Facilities</i> , ed. 6, Rev. 1; Pamphlet 64, Rev. 1; The Chlorine Institute: Arlington, VA, 2008 .
65	<i>Personal Protective Equipment for Chlor-Alkali Chemicals</i> , ed. 5; Pamphlet 65; The Chlorine Institute: Arlington, VA 2008
66	<i>Recommended Practices for Handling Chlorine Tank Cars</i> , ed. 4; Pamphlet 66; The Chlorine Institute: Arlington, VA, 2009 .
72	<i>Properties of Chlorine in SI Units</i> , ed. 3; Pamphlet 72; The Chlorine Institute: Arlington, VA, 2011 .
73	<i>Atmospheric Monitoring Equipment for Chlorine</i> , ed. 7; Pamphlet 73; The Chlorine Institute: Arlington, VA, 2003 .
74	<i>Guidance on Complying with EPA Requirements under the Clean Air Act by Estimating the Area Affected by a Chlorine Release</i> , ed. 5; Pamphlet 74; The Chlorine Institute: Arlington, VA, 2012 .
76	<i>Guidelines for the Safe Motor Vehicular Transportation of Chlorine Cylinders and Ton Containers</i> , ed. 5; Pamphlet 76; The Chlorine Institute: Arlington, VA, 2012 .

<u>Pamphlet #</u>	<u>Title</u>
89	<i>Chlorine Scrubbing Systems</i> , ed. 3, Rev. 1; Pamphlet 89; The Chlorine Institute: Arlington, VA, 2008 .
100	<i>Dry Chlorine: Behaviors of Moisture in Chlorine and Analytical Issues</i> , ed. 4; Pamphlet 100; The Chlorine Institute: Arlington, VA, 2011 .
121	<i>Explosive Properties of Gaseous Mixtures Containing Hydrogen and Chlorine</i> , ed. 3; Pamphlet 121; The Chlorine Institute: Arlington, VA, 2009 .
152	<i>Safe Handling of Chlorine Containing Nitrogen Trichloride</i> , ed. 3; Pamphlet 152; The Chlorine Institute: Arlington, VA, 2011 .
155	<i>Water and Wastewater Operators Chlorine Handbook</i> , ed. 3; Pamphlet 155; The Chlorine Institute: Arlington, VA 2014 .
164	<i>Reactivity and Compatibility of Chlorine and Sodium Hydroxide with Various Materials</i> , ed. 2; Pamphlet 164; The Chlorine Institute: Arlington, VA 2007 .
165	<i>Instrumentation for Chlorine Service</i> , ed. 2; Pamphlet 165; The Chlorine Institute: Arlington, VA, 2009 .
166	<i>Reactivity and Compatibility of Chlorine and Sodium Hydroxide with Various Materials</i> , ed. 2; Pamphlet 164; The Chlorine Institute: Arlington, VA 2007 .
168	<i>Guidelines for Dual Valve Systems for Bulk Chlorine Transport</i> , ed. 1; Pamphlet 168; The Chlorine Institute: Arlington, VA, 2013 .
IB/A	<i>Instruction Booklet: Chlorine Institute Emergency Kit "A" for 100- and 150-lb. Chlorine Cylinders</i> , ed. 12; Pamphlet IB/A; The Chlorine Institute: Arlington, VA, 2013 .
IB/B	<i>Instruction Booklet: Chlorine Institute Emergency Kit "B" for Chlorine Ton Containers</i> , ed. 10; Pamphlet IB/B; The Chlorine Institute: Arlington, VA, 2009 .
IB/C	<i>Instruction Booklet: Chlorine Institute Emergency Kit "C" for Chlorine Tank Cars and Tank Trucks</i> , ed. 9; Pamphlet IB/C; The Chlorine Institute: Arlington, VA, 2009 .

11.2 U.S. GOVERNMENT REGULATIONS AND SPECIFICATIONS

All U.S. regulations and specifications are available from the Superintendent of Documents, U.S. Government Printing Office, Washington, D.C. 20401. www.gpo.gov

11.2.1 Code of Federal Regulations (CFR), Various Sections.

11.3 CANADIAN REGULATIONS

Most Canadian regulations can be obtained from the Canadian Government Publishing Center. publications.gc.ca

11.4 AMERICAN CONFERENCE OF GOVERNMENTAL INDUSTRIAL HYGIENISTS (ACGIH)

1330 Kemper Meadow Drive
Cincinnati, OH 45240
www.acgih.org

11.4.1 *Threshold Limit Values and Biological Exposure Indices*, Published Annually.

11.4.2 *Industrial Ventilation: A Manual of Recommended Practice for Design*, 28th Edition, 2013.

11.5 AMERICAN SOCIETY OF MECHANICAL ENGINEERS (ASME)

Two Park Avenue
New York, NY 10016-5990.
www.asme.org

11.5.1 *Rules for Construction of Pressure Vessels*, Sections VIII, Division ASME Boiler, and Pressure Vessel Code ANSI/ASME BPV-VIII- 1.

11.6 ASTM INTERNATIONAL (ASTM)

(Formerly American Society for Testing and Materials)
100 Barr Harbor Drive
P.O. Box C700
West Conshohocken, PA 19428-2959
www.astm.org

11.6.1 ASTM-E410 (2008), *Standard Method of Testing for Moisture and Residue in Liquid Chlorine*.

11.6.2 ASTM-E649 (2011), *Standard Test Method for Bromine in Chlorine*.

11.6.3 ASTM-E806 (2008), *Standard Test Method for Carbon Tetrachloride and Chloroform in Liquid Chlorine by Direct Injection (Gas Chromatographic Procedure)*.

11.6.4 ASTM-D2022 (2008), *Standard Methods of Sampling and Chemical Analysis of Chlorine-Containing Bleaches*.

11.7 COMPRESSED GAS ASSOCIATION (CGA)

14501 George Carter Way, Suite 103
Chantilly, VA 20151
www.cganet.com

11.7.1 Pamphlet C-1, *Methods for Pressure Testing Compressed Gas Cylinders*.

11.7.2 Pamphlet C-6, *Standard for Visual Inspection of Steel Compressed Gas Cylinders*.

11.7.3 Pamphlet P-1, *Safe Handling of Compressed Gases in Containers*.

-
- 11.7.4 Pamphlet V-1, *Standard for Compressed Gas Cylinder Valve Outlet and Inlet Connections* (This pamphlet is also designated as ANSI B57.1 and CSA b96.)
- 11.8 NATIONAL ACADEMY OF SCIENCES (NAS)
- Printing and Publishing Office
500 Fifth Street, NW
Washington, DC 20001
www.nationalacademies.org
- 11.8.1 Water Chemicals Codex, 1982.
- 11.9 NATIONAL FIRE PROTECTION ASSOCIATION (NFPA)
- Batterymarch Park
Quincy, MA 02169
www.nfpa.org
- 11.10 NATIONAL INSTITUTE OF OCCUPATIONAL SAFETY AND HEALTH (NIOSH)
- 1600 Clifton Road
Atlanta, GA 30333
www.cdc.gov/niosh/
- 11.10.1 *Pocket Guide to Chemical Hazards*, U.S. Department of Health and Human Services: 2010.
- 11.11 NSF INTERNATIONAL
- 789 N. Dixboro Road
Ann Arbor, MI 48105
www.nsf.org
- 11.11.1 *NSF/ANSI Standard 60 - Drinking Water Treatment Chemicals-Health Effects*; updated annually.
- 11.12 U.S. PHARMACOPEIAL CONVENTION
- 12601 Twinbrook Parkway
Rockville, MD 20852
<http://www.usp.org/>
- 11.12.1 *Food Chemicals Codex V*, Ninth Edition, 2014

CHLORINE

The Essential Element

Over 240 years ago, a young Swedish researcher, Carl Wilhelm Scheele, discovered chlorine. Because of its reactivity and bonding characteristics, chlorine has become a popular building block in chemistry and it is essential in everyday life. Drinking water, agricultural abundance, disinfected wastewater, essential industrial chemicals, bleaches, and fuels all depend on chlorine. Pharmaceuticals, plastics, dyes, cosmetics, coatings, electronics, adhesives, clothing, and automobile parts are examples of product groups that depend on chlorine chemistry.

PRODUCTS OF CHLORINE CHEMISTRY

Automotive

Air Bags
Brake Fluids
Bumpers
Dashboards
Floor Mats
Hoses, Belts and Wires
Instrument Panels
Paint
Seat Belts
Seat Cushions
Tire Cord

Construction

Carpeting
Coatings
Flooring
Paints
Pipes
Upholstery
Vinyl Siding
Wire Insulation

Defense

Bullet-Resistant Glass
Bullet-Resistant Vests
Helmets
Jet Engine Blades
Missiles
Parachutes
Riot Shields
Water Repellant Fibers

Electronics

CDs, DVDs
Fiber Optic Glass
Semiconductors
Wire Insulation

Food Production & Handling

Crop Protection Chemicals
Sterile Packaging
Surface Sanitizers
Thermal Insulation
Vitamins B1 & B6

Health Care

Artificial Joints
Cleaning Compounds
Electronic Instruments
Laboratory Reagents
Prescription Eye Wear
Sterile Packaging
Surgical Supplies

Medicines

Antibiotics
Antihistamines
Cancer Treatment
Decongestants
Local Anesthetics
Pain Relievers

Metal Production

Bismuth
Magnesium
Nickel
Titanium
Zirconium
Zinc

Outdoor Recreation

Backpacks
Coats
Golf Club Grips
Inflatable Rafts
Neoprene Wet Suits
Nylon Ropes
Sleeping Bags
Surf Boards
Swimming Pool Disinfection
Tents
Waterproof Clothing

Water Treatment

Safe Drinking Water
Wastewater Treatment

DRAWINGS

DRAWING 122-2: TON CONTAINER LIFTING BEAM

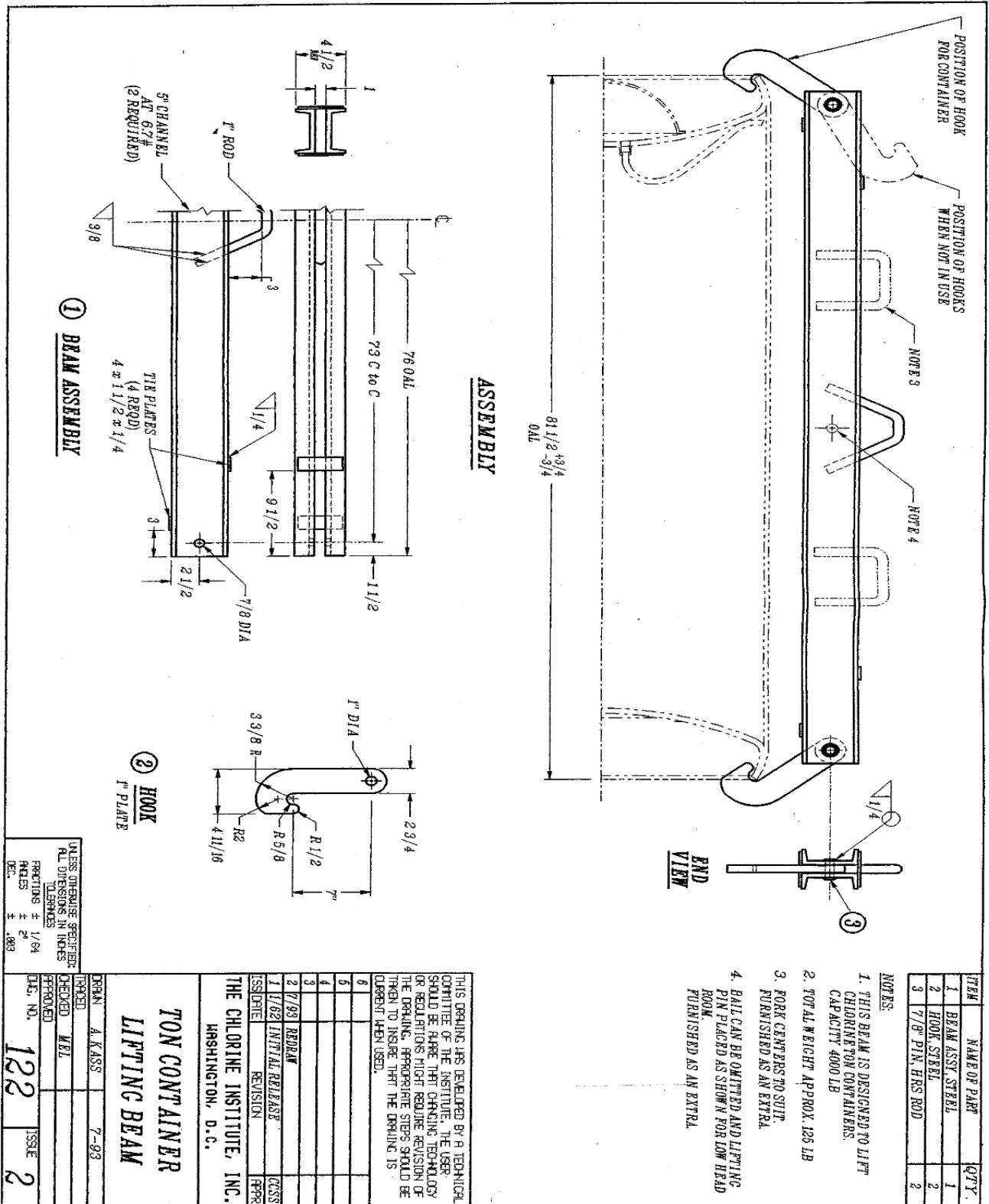

DRAWING 183-3: MANIFOLDING TON CONTAINERS FOR LIQUID CHLORINE WITHDRAWAL

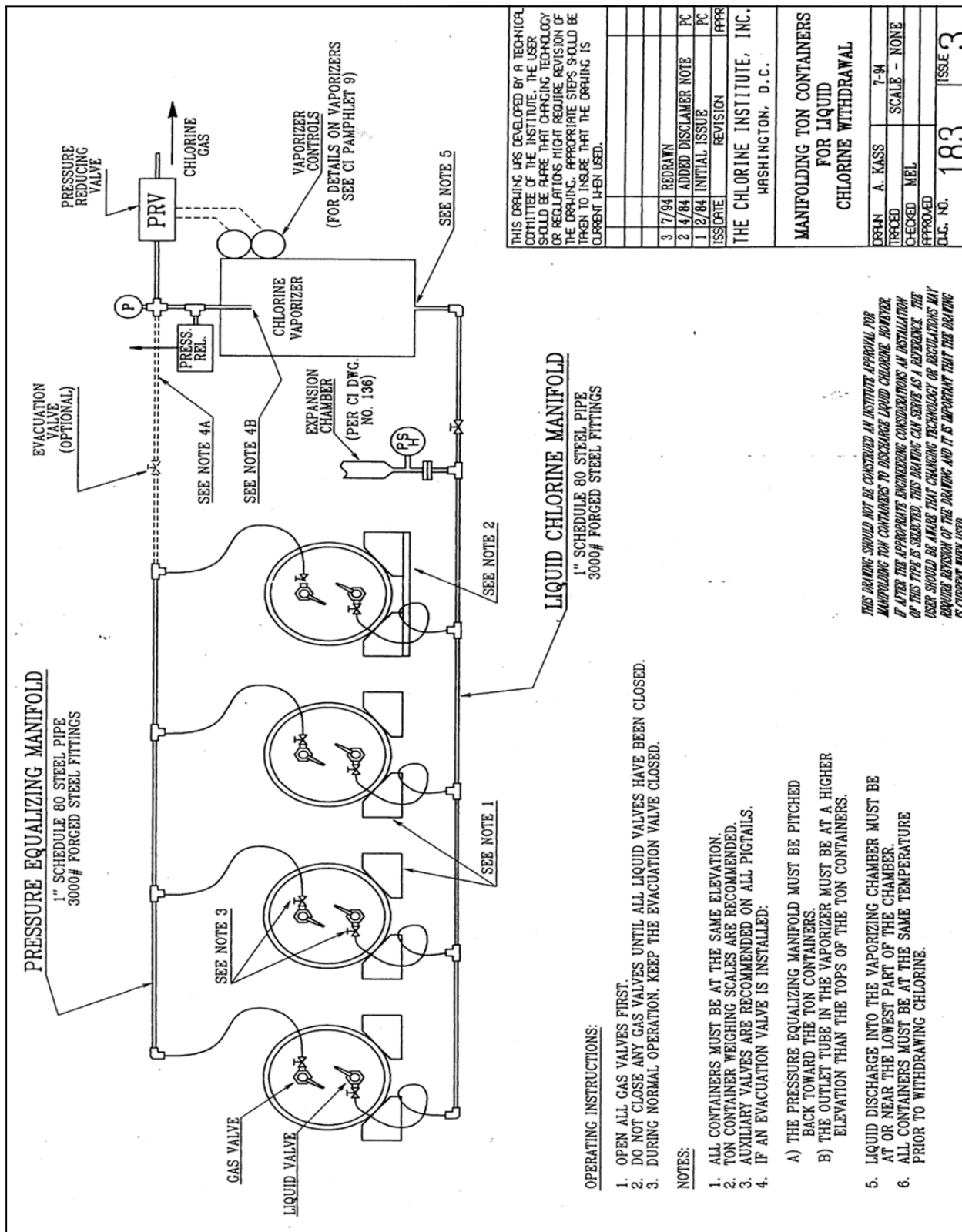

THIS DRAWING WAS DEVELOPED BY A TECHNICAL COMMITTEE OF THE INSTITUTE. THE USER SHOULD BE AWARE THAT CHANGING TECHNOLOGY OR REGULATIONS MIGHT REQUIRE REVISION OF THE DRAWING. APPROPRIATE STEPS SHOULD BE TAKEN TO INSURE THAT THE DRAWING IS CURRENT WHEN USED.

3/7/84	REDRAWN	PC
2/14/84	ADDED DISCLAIMER NOTE	PC
1/12/84	INITIAL ISSUE	PC
ISSUOR	REVISION	FFPR

THE CHLORINE INSTITUTE, INC.
WASHINGTON, D.C.

MANIFOLDING TON CONTAINERS FOR LIQUID CHLORINE WITHDRAWAL

DESIGN	A. KASS	7-94
TRACED		SCALE - NONE
CHECKED	MEL	
APPROVED		
DWG. NO.	183	ISSUE 3

DRAWING 189-2: CLOSED YOKE CHLORINE CONTAINER VALVE

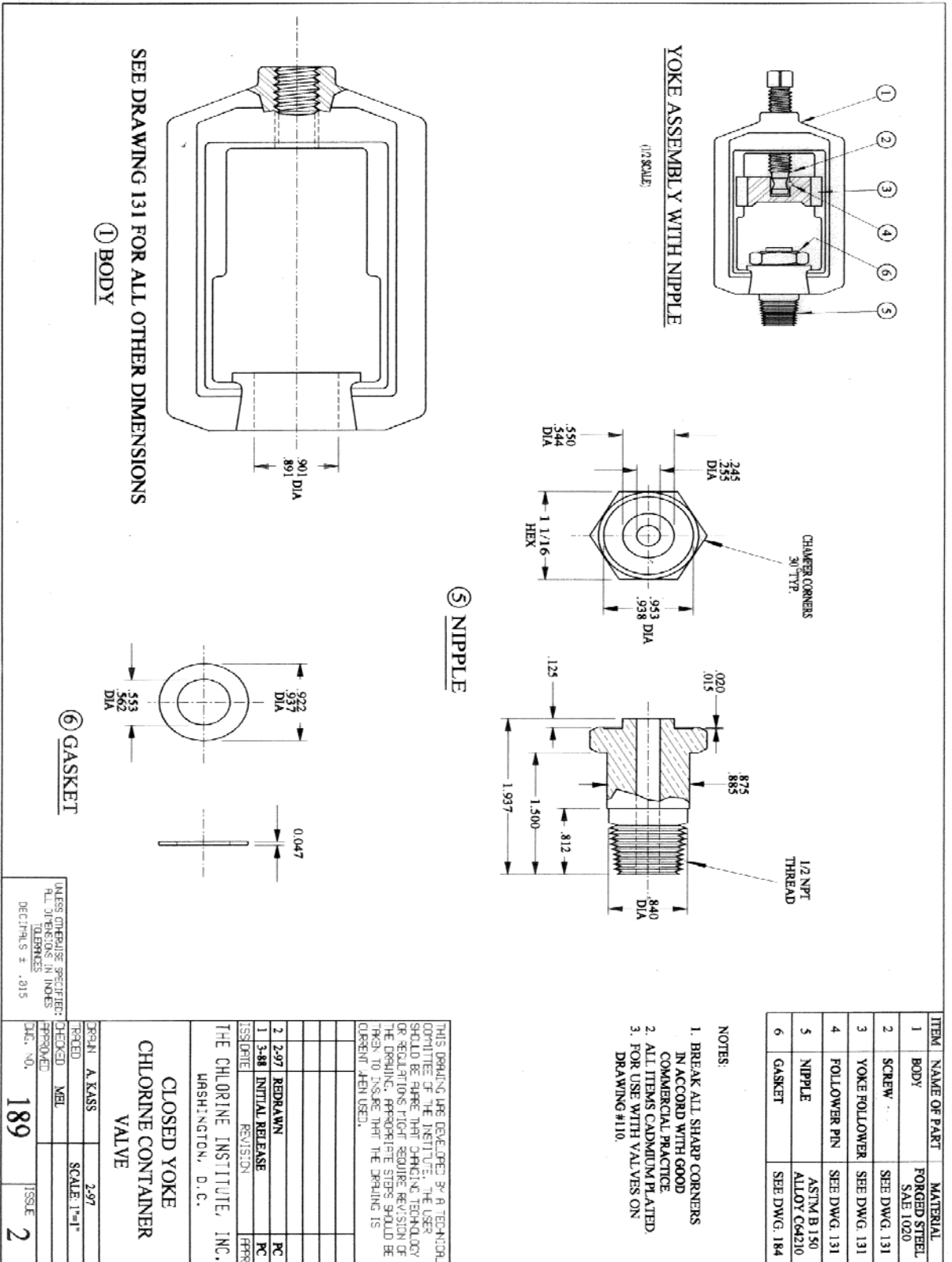

ITEM	NAME OF PART	MATERIAL
1	BODY	FORGED STEEL SAE 1020
2	SCREW	SEE DWG. 131
3	YOKE FOLLOWER	SEE DWG. 131
4	FOLLOWER PIN	SEE DWG. 131
5	NIPPLE	ASTM B 150 ALLOY C64210
6	GASKET	SEE DWG. 184

- NOTES:
1. BREAK ALL SHARP CORNERS IN ACCORD WITH GOOD COMMERCIAL PRACTICE
 2. ALL ITEMS CADMIUM PLATED
 3. FOR USE WITH VALVES ON DRAWING #110.

THIS DRAWING WAS DEVELOPED BY A TECHNICAL COMMITTEE OF THE INSTITUTE. THE USER SHOULD BE AWARE THAT CHANGING TECHNOLOGY OR REGULATIONS MIGHT REQUIRE REVISION OF THE DRAWING. APPROPRIATE STEPS SHOULD BE TAKEN TO INSURE THAT THE DRAWING IS CURRENT WHEN USED.

2	2-97	REDRAWN	PC
1	3-88	INITIAL RELEASE	PC
ISSUANCE		REVISION	PPR

THE CHLORINE INSTITUTE, INC.
WASHINGTON, D. C.

DESIGN	A. KASS	2-97
CHECKED	MBL	SCALE 1"=1"
APPROVED		
DWG. NO.	189	ISSUE
		2

UNLESS OTHERWISE SPECIFIED:
ALL DIMENSIONS IN INCHES
TOLERANCES:
DECIMALS ± .015



1300 Wilson Boulevard « Suite 525 « Arlington, VA 22209
Telephone: (703) 894-4140 « Fax: (703) 894-4130
Email: pubs@CL2.com « Website: www.chlorineinstitute.org
Technical inquiries: techsvc@cl2.com

©The Chlorine Institute all rights reserved.